

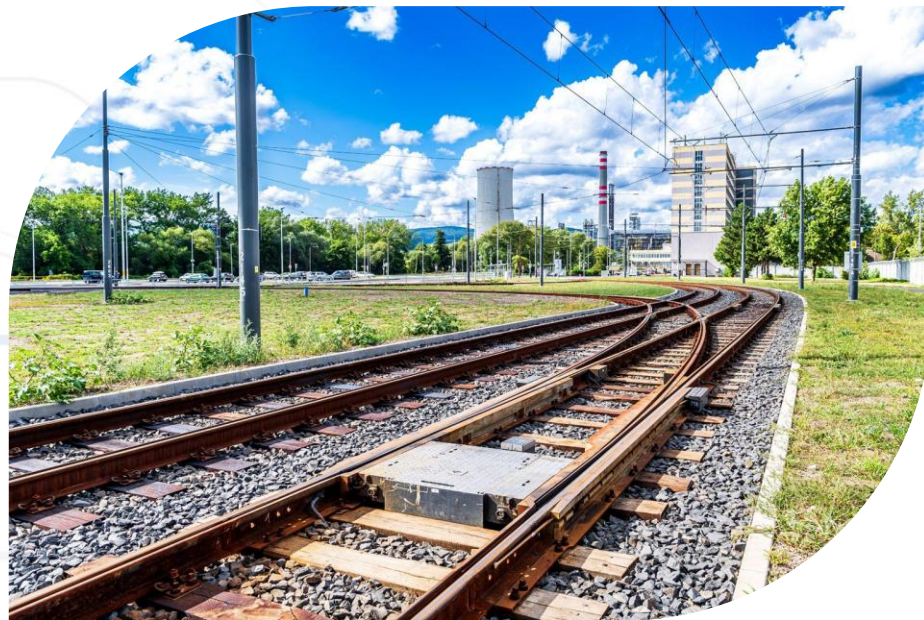

Pražská strojírna a.s.

COMPANY PRESENTATION



...all for the modern tramway track

# Contents

- History
- Present
- Subject of activity
- Products and services
- Implementation worldwide
- Contacts
- Foreign partners
- Production site
- Certification
- Metrology
- Point systems
- Tram switches
- Tram turnouts and complete crossings
- Tram track accessories
- Tram wheels and wheel tyres
- Designe work
- Service and training
- Rail surfacing – re-shaping of the rail
- Welding of rails under flux



# History

Pražská strojírna a.s. is a company with a long tradition of engineering production **since the early 1830s**. Since 1912, when the Board of Directors of the electric company proposed to the city council to purchase the factory, “Pražská akciová společnost” has been an integral part of public transport in Prague. **On April 1, 1994**, it was decided to transform Dopravní podnik hl. m. Prahy, a.s. and a joint-stock company **was founded** under the business name **“Pražská strojírna a.s.”**



# Present

"Pražská strojírna a.s. has undergone successful restructuring in recent years and, thanks to massive investments in machinery, Pražská strojírna has managed to increase labor productivity and achieve excellent economic results. We are gradually modernizing our CNC machine tool fleet, we have invested in a welding robot, and we are building a new hall to expand our production capacity. We are also investing in the working environment for employees, the production halls have received new energy-saving lighting, and we have installed a photovoltaic power plant on the roofs of all buildings. Our ambition is to be a modern engineering company in Prague supplying all products and services for the tram superstructure of modern tram lines, not only in Prague and the Czech Republic, but also abroad."



# Subject of activity

The main activity is the development and production of track structures and switch systems for tram transport. Pražská strojírna also provides a complete service of switch systems, which is supplemented by other complements, such as tram switches with flexible switch tongues in various modifications according to customer requirements, switch heating, track drainage and other engineering production. Its own development team is then ready to solve even the most complex problems in the field of urban and suburban rail transport and, with a fleet of mobile welding workshops, is able to solve various repairs and replacements directly in the field.

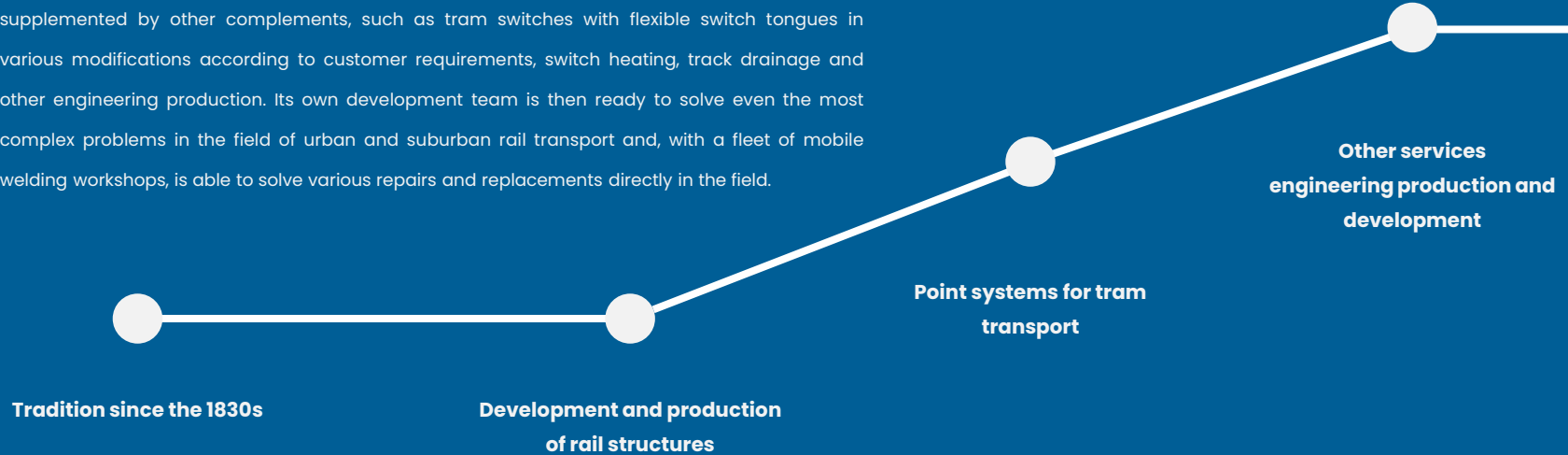

# Products and services



## Point systems

- Automatic point systems
- Manual point systems
- Point systems for depots



## Switches

- block switch
- switch with flexible blades
- switch with replaceable blades
- gauntlet switches
- single-point switches



## Turnouts

- Tournouts with a straight section in the branching direction
- Tournouts with a curved section in the branching direction
- portable cross-over



## Crossings

- crossings
- Tramway crossing with railway siding
- Other other special track structures



## Trackside equipment

- transition and expansion rails
- drainage
- heating of switches
- profiles  
Spurrillenschiene Form S49 Krug



## Wheels and wheel tyres

New tram wheels and machined wheel rims for tram vehicles in various profiles and types according to customer requirements



## Design work

Development and production of railway crossings and complete track superstructure accessories, using our own top-notch design capacity.



## Sales services

- Service and repair activities
- Welding and grinding

# Implementation worldwide

Algeria

Australia

Belgium

Belorussia

Bulgaria

Czech republic

Estonia

Italy

Canada

Latvia

Hungary

Germany

Norway

New Zealand

Austria

Rumania

Russia

Greece

Slovakia

Serbia

Spain

Sweden

Switzerland

Tunisian

USA

# Realization



# Realization

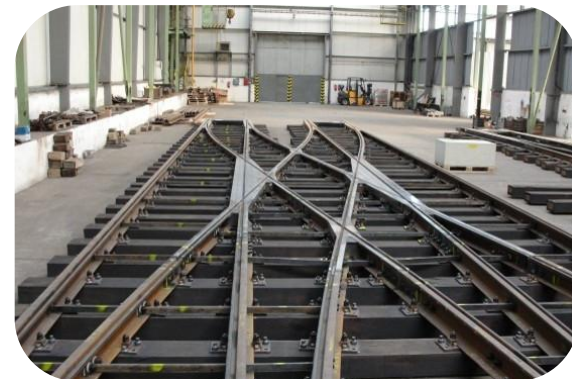

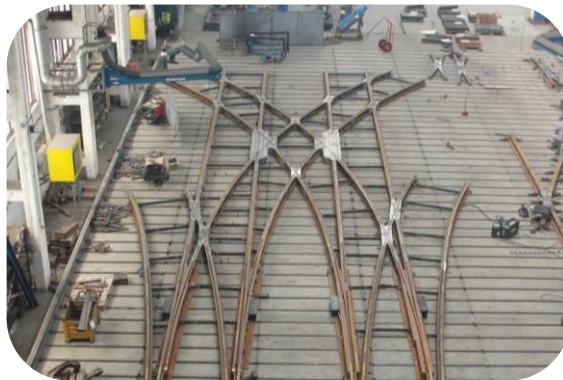

# Realization



# Contacts



Robert Masarovič

-  Chairman of the Board of Director
-  +420 283 112 201
-  robert.masarovic@pstroj.cz



Jiří Dědek

-  Financial Manager
-  +420 283 112 204
-  jiri.dedek@pstroj.cz



Miroslav Kolář

-  Business Manager
-  +420 283 112 220
-  kolar@pstroj.cz



Dušan Bloščica

-  Chief Technical Officer
-  +420 283 112 275
-  bloscica@pstroj.cz



Petr Kahoun

-  Production Manager
-  +420 283 112 282
-  kahoun@pstroj.cz



Vítek Kulháněk

-  Quality Manager
-  +420 283 112 228
-  kulhanek@pstroj.cz



Jan Nováček

-  Head of Service center
-  +420 778 962 089
-  jan.novacek@pstroj.cz



Martin Vaněk

-  Purchasing Manager
-  +420 283 112 224
-  vanek@pstroj.cz



Pavλίna Fenclová

-  Personnel Department
-  +420 283 112 340
-  person@pstroj.cz

Ester Šamajová

-  Legal representation, compliance
-  +420 728 820 396
-  schranka.duvery@pstroj.cz

Roman Šantavý

-  Media representative
-  +420 724 101 396
-  media@pstroj.cz



**Australia**  
**YARRA TRAMS**  
[www.yarratrams.com.au](http://www.yarratrams.com.au)

 E-Gate – Footscray Road Melways  
Map 2E  
C1 West Melbourne  
VIC 3001

 Massoud Majidi

 +61 412 366 230

 [massoud.majidi@yarratrams.com.au](mailto:massoud.majidi@yarratrams.com.au)

**Germany**  
**Mahn Bahntechnik GmbH**  
[www.mahn-bahntechnik.com](http://www.mahn-bahntechnik.com)

 Eichenriede 9  
31311 Uetze

 Manfred Mahn

 +49 172 7522270

 [manfred.mahn@mahn-bahntechnik.com](mailto:manfred.mahn@mahn-bahntechnik.com)

**Estonsko a Lotyšsko**  
**Maksmi OÜ**  
[www.maksmi.ee](http://www.maksmi.ee)

 Peterburi tee 46  
Harju county  
11415 Tallinn

 Ruudo Liis

 +372 5091144

 [ruudo@maksmi.ee](mailto:ruudo@maksmi.ee)

**Tunesia**  
**Lassad Bouzguenda**

 101, Avenue Hédi Nouira Résidence  
Essafa  
Appt. A22 – Ennasr II  
2037 Ariana

 Lassad Bouzguenda

 +216 22 788 888

 [lassad.bouzguenda@free.fr](mailto:lassad.bouzguenda@free.fr)

**Russia + Belarus**  
**MT – Transkomplekt Ltd.**  
[www.mt-tk.by](http://www.mt-tk.by)

 Borisov, Dneprovskaya str., 58  
222519 Minsk

 Nikolai Sobol

 +375 29 863 36 99

 [nikolai@mt-tk.by](mailto:nikolai@mt-tk.by)

# Production area

Mladoboleslavská 133  
Praha 9 - Vinoř



warehouse and maintenance

warehouse

production hall and administrative building

outdoor mounting surface

outdoor mounting surface

assembly hall

outdoor mounting surface

# Certification

## Pražská strojírna a.s.

introduced and certified the ISO 9001 quality management system in 1997. Subsequently, in 2008, we obtained the ČSN EN ISO 3834-2 welding process certificate and the ISO 14001 environmental protection system certificate. Pražská strojírna a.s. pays attention to the ecological aspect of production and a positive relationship with the environment. We have also obtained the OHS management system in accordance with the ISO 45001:2018 certificate to our company processes. In 2021, our company was included in the Avetta system, which is a system for assessing suppliers' compliance with safety and work risk requirements, and this system is used primarily for suppliers for the Australian market. We also hold welding certificates issued by the Association of Transport Companies of the Czech Republic, the German Welding Institute in Hannover, and last but not least, a certificate according to ISO 37301.



# Metrology

**Pražská strojírna a.s.** has an established metrological system for checking and controlling the measuring instruments used, both within its engineering production and within the scope of service and maintenance work carried out on tram lines.

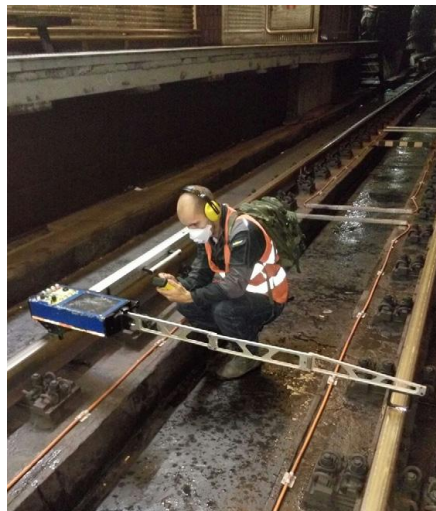

# Point systems

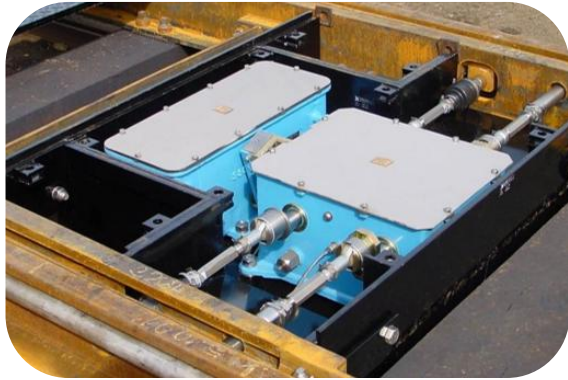

automatic point system VSP-1-K

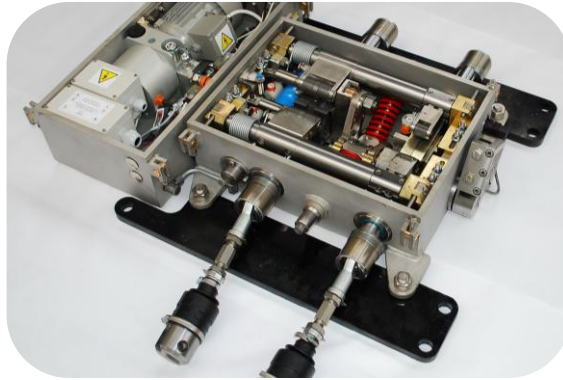

automatic point system VSP-12-K



manual point system VS-20

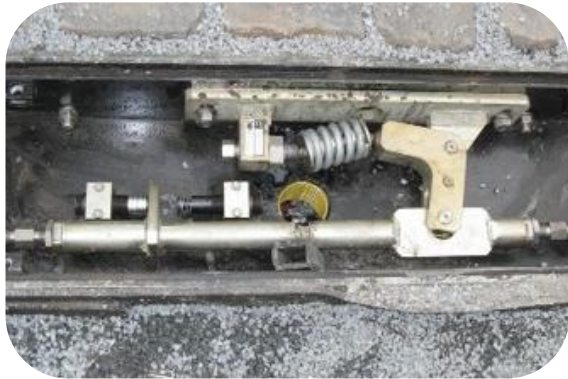

manual point system VS-21



point system VSP-20 for depots



training, service and maintenance

## Automatic pointing machine VSP-1-K

Setting device VSP-1-K is designed for mechanized resetting of the turnouts with flexible blades to required end positions.

VSP-1-K is ecologically friendly, meets high level of cross-over safety (SIL 3 requirements for safety integrity according to EN 61508) and features long life with minimum maintenance demands.

A setting system can be adapted to needs and requirements of individual customers.

### Securing:

- down-pressure of the setting rod in both extreme positions
- locking the setting rod in both extreme positions
- signalling both extreme positions of both checking rods
- signalling of blocking the command for resetting when inserting the key into setting pocket
- deformation-free force resetting ("force open")
- optionally, the turnout system includes diagnostic elements (oil pressure and oil level measurement, turnout system, flooding sensor and other options as ordered by the user)



Electro-magnetic power device EMP-44.



Electro-hydraulic power device EHP-41.

# Automatic pointing machine VSP-1-K

## Description:

- 1 – Earth case
- 2 – Earth case covers
- 3 – Patented pointing mechanism ZK-75
- 4 – Setting rods
- 5 – cecking rods
- 6 – Electro-magnetic power device EMP-44 with damper DD-100 or Electro-hydraulic EHP-40 power device
- 7 – Damper DD-100

Device is waterproof.

All used materials guarantee high reliability and moisture resistance. Central drainage in earth case allow connection to track drainage system.

This device may be equipped by including diagnostic elements for monitoring hydraulic pressure, hydraulic oil level, flood, throw-over time, throw-over events, temperature in the turnout system and others that communicates with automatic diagnostic system.

## Technical parameters:

Minimum track gauge	1000 mm
Lift of changeable switch blades	36 to 75 mm
Connection setting rod/tongue	according turnout type
Setting force on the rod	approx. 5 kN
Press-down force of spring mechanism	1,3 až 2,2 kN
Minimum setting moment	50 to 250 Nm
Time of mechanized setting (adjustable)	0,6 to 1,5 s
Operational voltage of electro-magnetic power device	600 / 750 V DC
Operational voltage of electro-hydraulic power device	600 / 750 V DC
	230 / 400 V AC, 110 V AC 60 Hz
Normal current at 600 V DC	max. 10,5 A
Control voltage (control-free position sensors)	24 V DC
Permitted axle load on earthcase cover	12 000 kg
Earth case cover weight	70 kg
Overall weight	approx. 630 kg

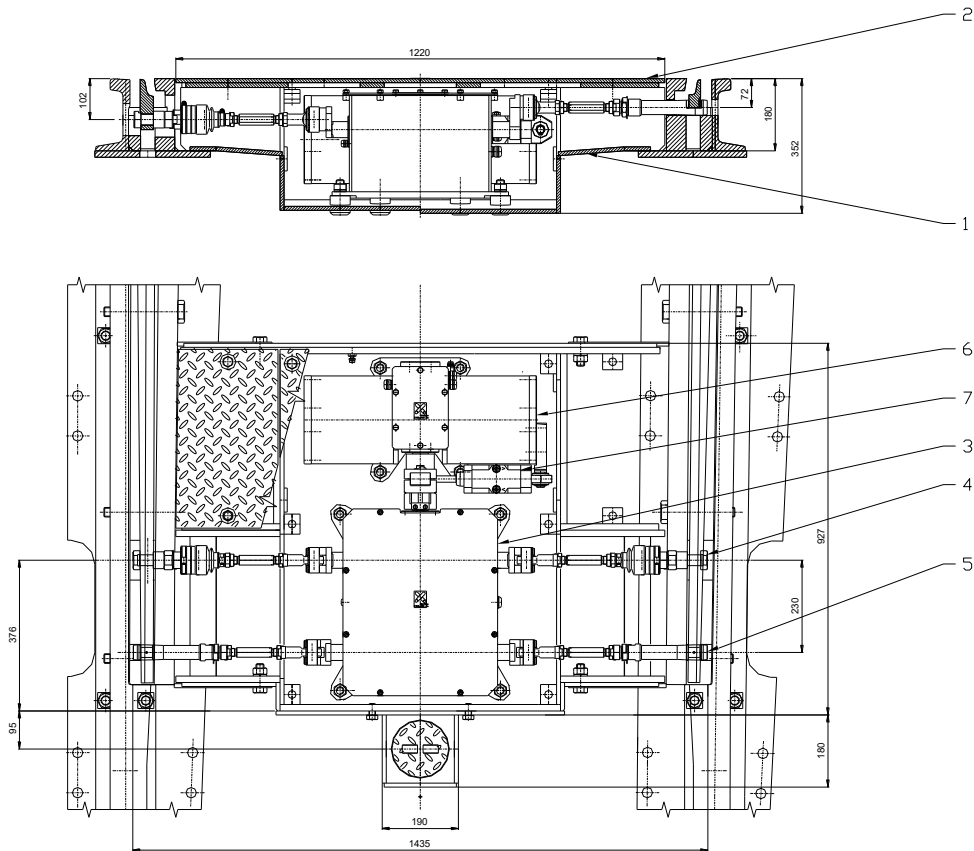

## Automatic pointing machine VSP-12-K

Setting device VSP-12-K is designed for mechanized resetting of the turnouts with flexible blades to required end positions. VSP-12-K is ecologically friendly, meets high level of cross-over safety (SIL3 requirements for safety integrity according to EN 61508) and features long life with minimum maintenance demands.

Main advantage of this setting device is combination of low installation depth (only 170mm) and long lifting of turnout blades (up to 100mm).

This type of switch mechanism is designed as two-box system – detachable box modules (mechanical and electro-hydraulic power box) with variable power requirements – 600V DC, 750V DC, 400V AC, 230V AC, 110V AC 60Hz or 24V DC.

### Securing:

- down-pressure of the setting rod in both extreme positions
- locking the setting rod in both extreme positions
- signalling both extreme positions of both checking rods
- signalling of blocking the command for resetting when inserting the key into setting pocket
- deformation-free force resetting (“force open”)
- optionally, the turnout system includes diagnostic elements (oil pressure and oil level measurement, turnout system, flooding sensor and other options as ordered by the user)

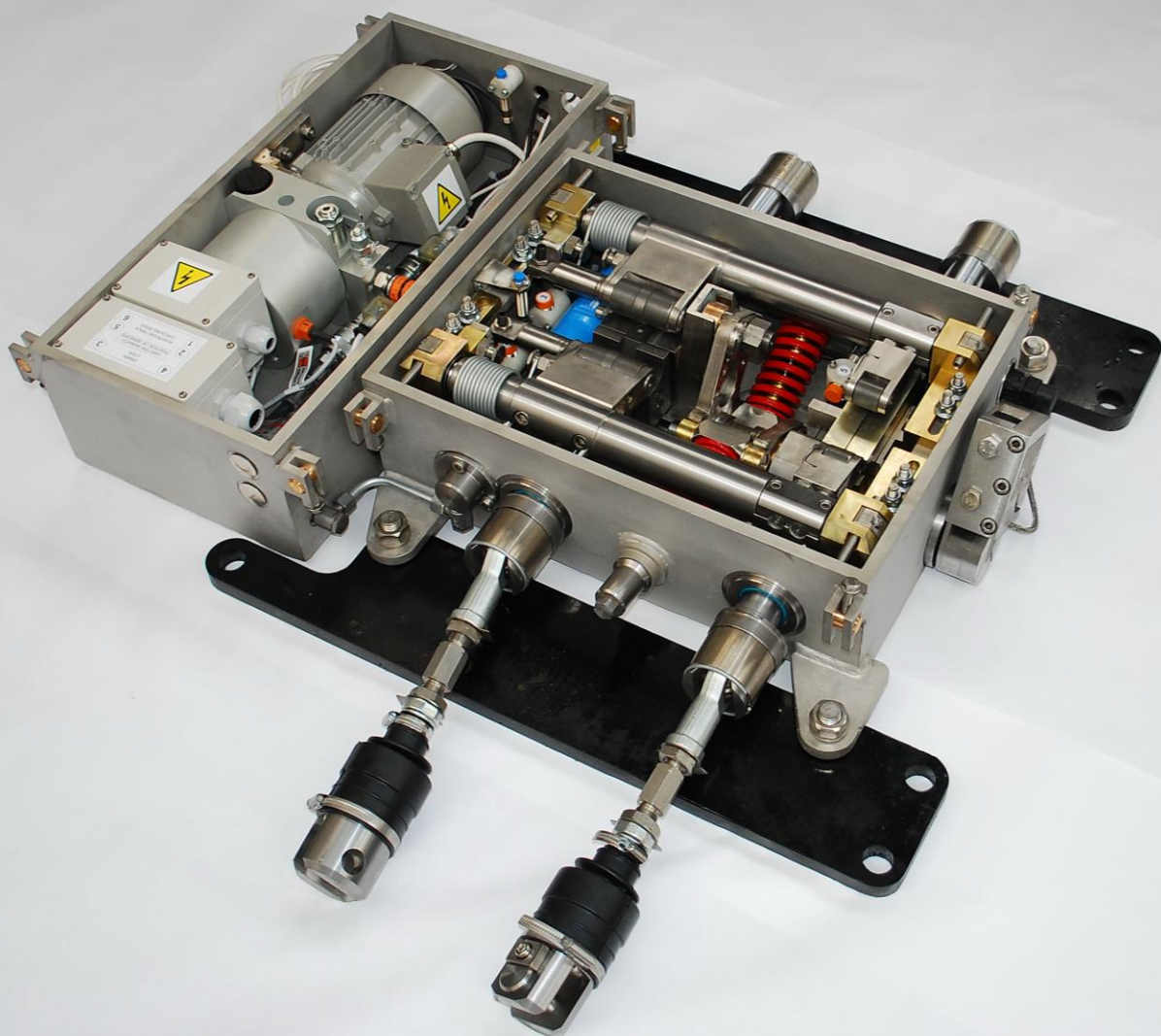

# Automatic pointing machine VSP-12-K

## Description:

The VSP-12-K switch system consists of the ZZKP-100-RO switch box, the JH-3-400-M waterproof separate electro-hydraulic unit, and the control system for the positioning and checking rods. The switch box can be fitted either with a standard split release or a split across the distant switch blade. The switch system can be installed loosely within an open line or it can be installed in an embedded box with drainage and lid capacity of 12 tonnes to allow passage of road vehicles.

Upon request, Pražská Strojirna a.s. supplies the turnout system including diagnostic elements to measure current oil pressure; record its maximum in collaboration with the control system; measure the throwing-over time in collaboration with control system; measure temperature in the turnout system; install a turnout system flooding sensor and other diagnostic options as ordered by the user.

## Technical parameters:

Minimum track gauge	1000 mm
Lift of changeable switch blades	36 to 100 mm
Connection setting rod/tongue	according turnout type
Connection checking rod/tongue	according turnout type
Setting force on the rod	approx. 5 kN
Minimum force-opening	10 kN + 30 %
Press-down force of spring mechanism	1,3 to 2,2 kN
Moment for manual throwing-over	150 to 250 Nm
Time of mechanized setting (adjustable)	1 to 2 s
Operational voltage of electro-hydraulic power device	600V DC, 750V DC, 400V AC, 230V AC, 110V AC 60Hz
Control voltage (control-free position sensors)	24 V DC

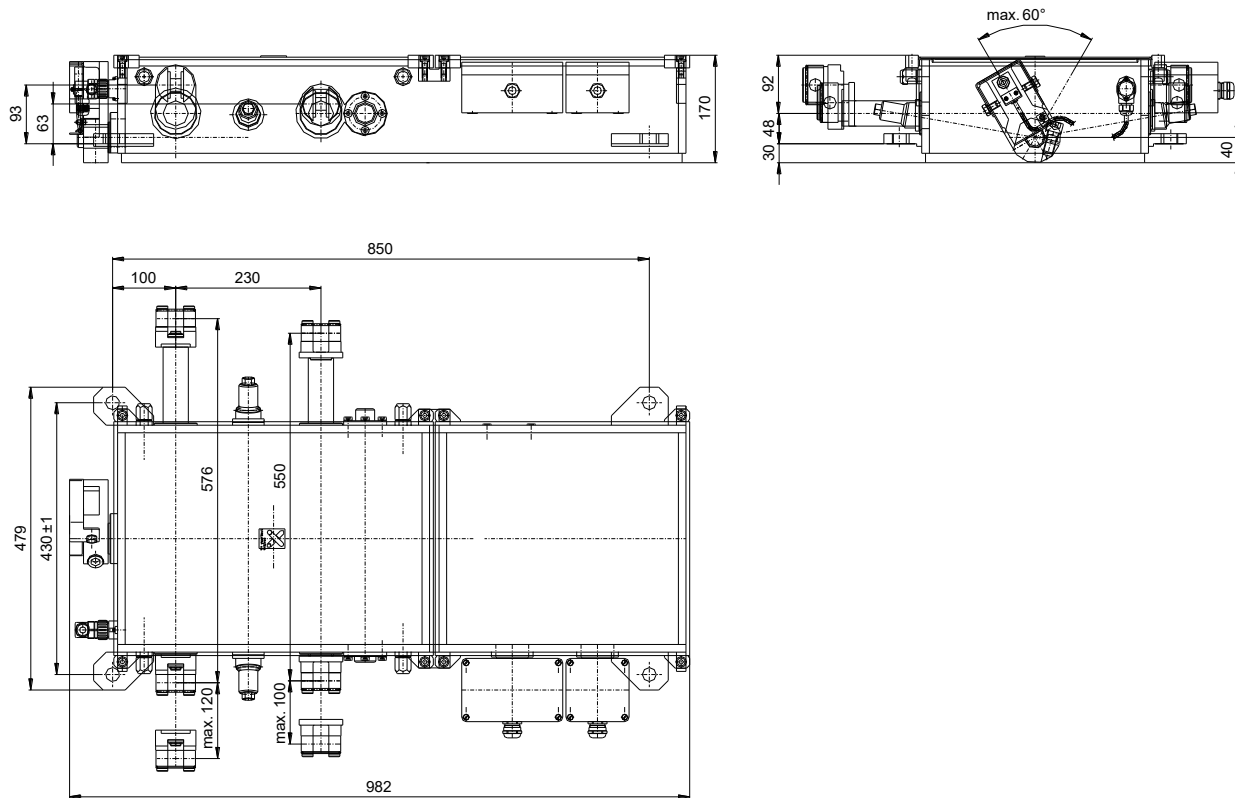

## Manual pointing machine VS-20

Setting device VS-20 is designed for holding blades of trailing direction turnouts in end positions. The standard setup secures blades in position that is given by the last tramway passage. Reversible adjustment reverses blades after the tram passage back to a preselected position, which is done by the position of the setting pocket.

VS-20 is ecologically friendly, guarantees noiseless function, and features a long life with minimum maintenance requirements. A Setting system can also be supplied in the design for single blade turnouts in alternatives for placement inside or outside to the track assembly.

The Setting system can be extended by the optional set of the blade position signaling sensors.

### Securing:

- a) in normal connection: down-pressure of the setting rod into position given by the last passage
- b) in reverse connection: down-pressure of the setting rod into position preselected by resetting the setting pocket.



# Manual pointing machine VS-20

## Description:

1 – Earth case                      2 – Earth case cover  
 3 – Patented pointing mechanism Z-60  
 4 – Setting rod                      5 – Two impact dampers

Device can be equipped by adaptor set with position sensors. All used materials guarantee high reliability and moisture resistance. Central drainage in earth case allow connection to track drainage system.

## Technical parameters:

Minimum track gauge	1000 mm
Lift of changeable switch blades	36 to 70 mm
Press-down force of flexible mechanism	0.85 to 3.17 kN (normal connection)
Press-down force of spring mechanism	1 to 3.2 kN (reversible connection)
Connection setting rod/tongue	according turnout type
Manual setting moment	170 to 420 Nm
Permitted axle load on earthcase cover	12000 kg
Earth case cover weight	58 kg
Overall weight approx.	approx. 250 kg

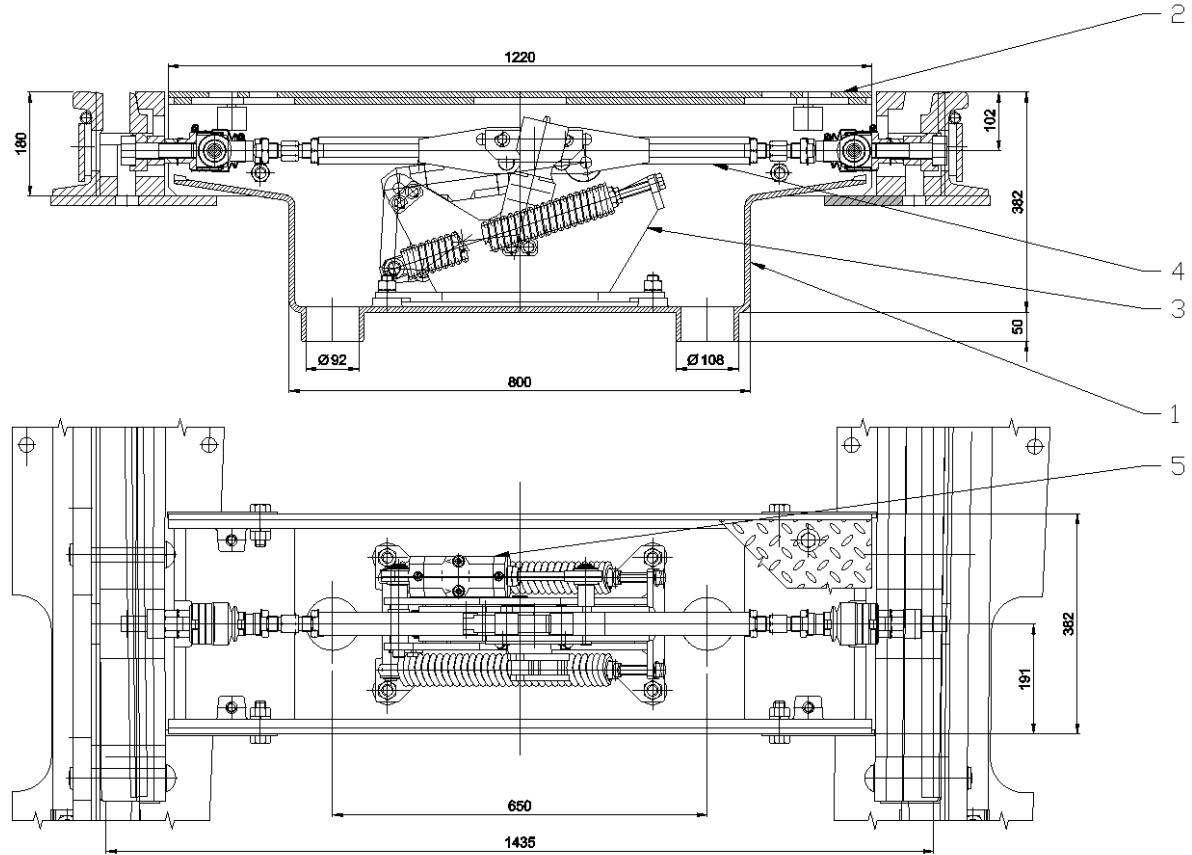

## Manual pointing machine VS-21

Setting device VS-21 is designed for holding blades of trailing direction turnouts in end positions. VS-21 is ecologically friendly, guarantees noiseless function and features long life with minimum maintenance demands.

### Securing:

- down-pressure of the setting rod to the position given by the last passage,
- the setting device can be completed by signalling the position of the blades.

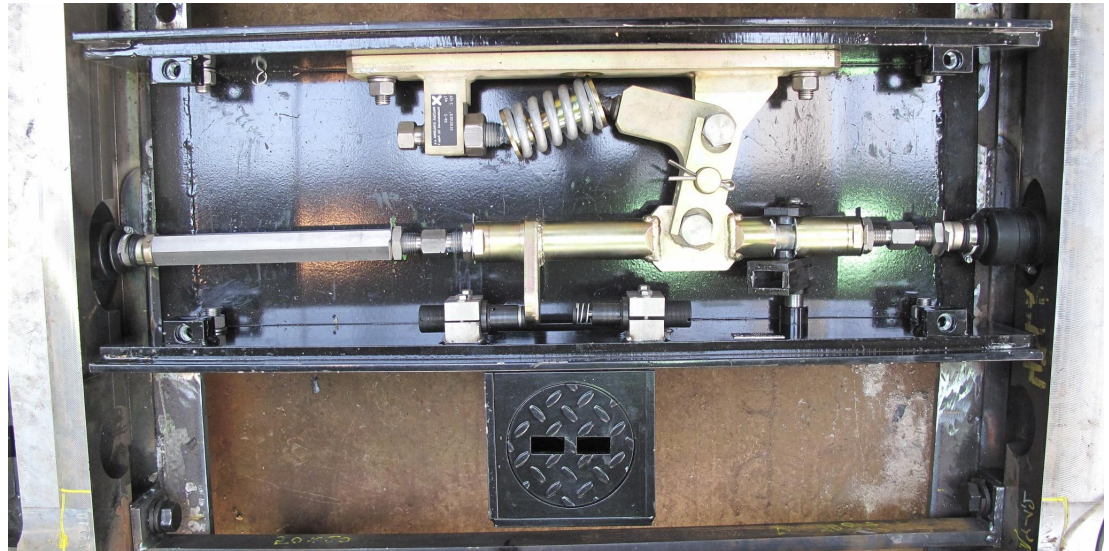
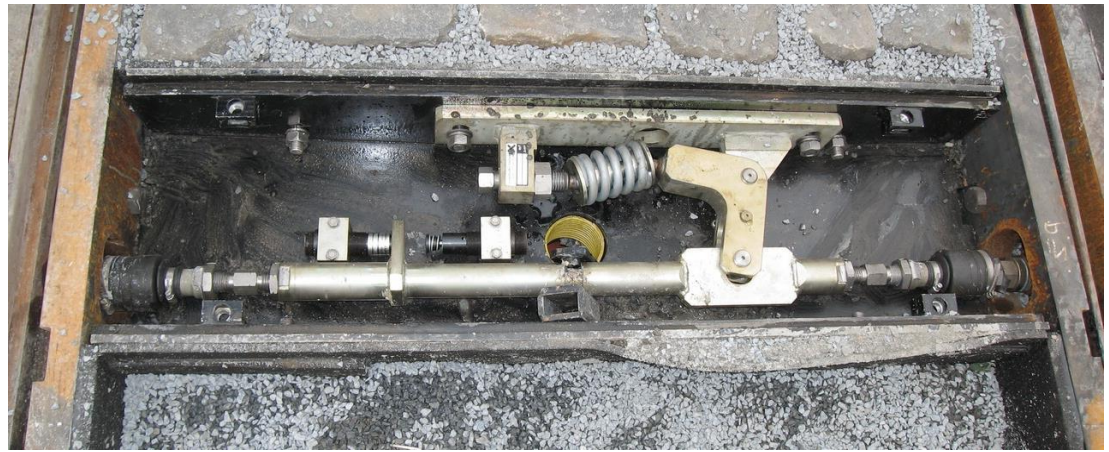

# Manual pointing machine VS-21

## Description:

1 - Earth case                      2 - Earth case covers  
3 - Patented pointing mechanism Z-75-R  
4 - Setting rod  
5 - Electro-magnetic power device with damper  
or Electro-hydraulic power device  
Device can be equipped by adaptor set with  
position sensors.  
All used materials guarantee high reliability and  
moisture resistance.  
Central drainage in earth case allow connection  
to track drainage system.

## Technical parameters:

Minimum track gauge	1000 mm
Lift of changeable switch blades	36 to 60 mm
Press-down force of flexible mechanism	max. 4 kN
Connection setting rod/tongue according turnout type	
Manual setting moment	100 to 250 Nm
Permitted axle load on earthcase cover	12000 kg
Earth case cover weight	40 kg
Overall weight approx.	200 kg

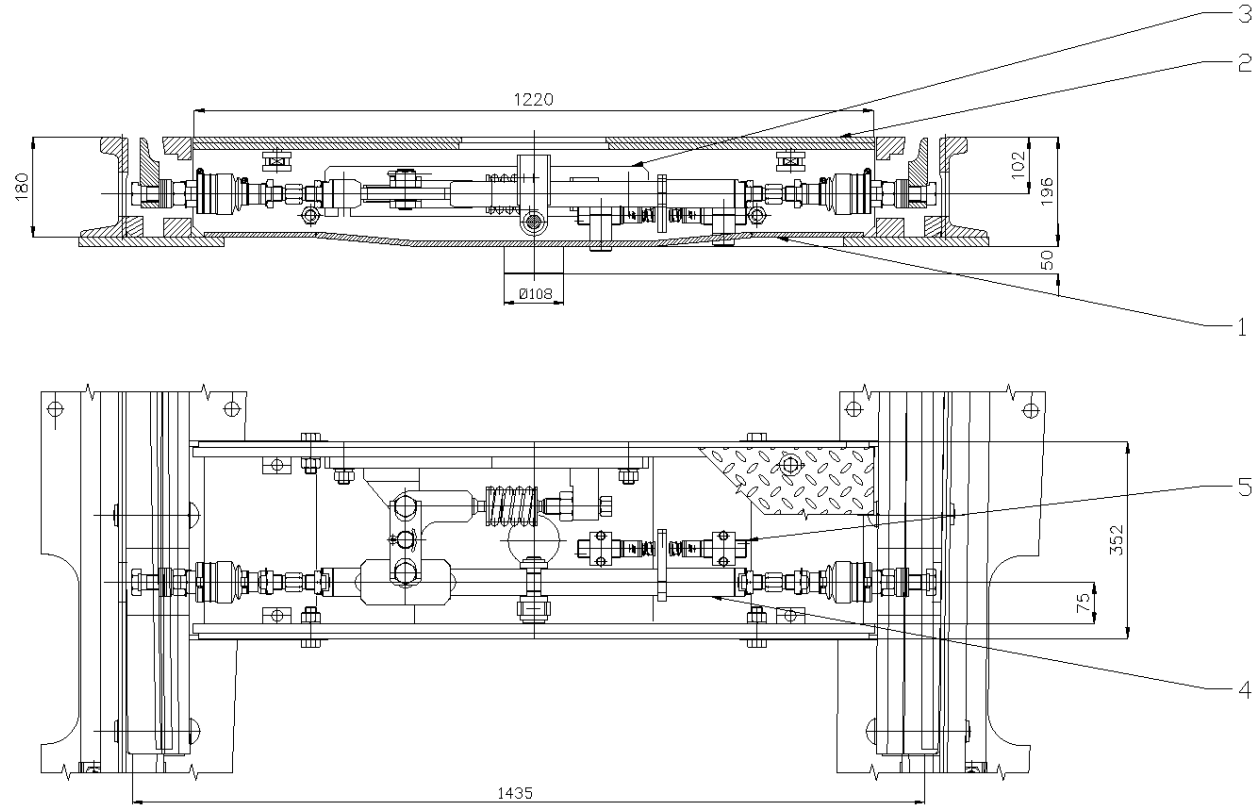

## Motorized pointing machine VSP-20

Setting device VSP-20 is designed for mechanized or manual resetting of the turnouts with flexible blades to required end positions. VSP-20 is ecologically friendly, guarantees noiseless function and features long life with minimum maintenance demands. A setting system can be supplied also in design for single blade turnouts in alternatives for placement inside or sideway to the track gauge. The setting system can be extended by optional set of blade position signaling sensors.

### Securing:

- down-pressure of the setting rod to the position given by the last passage,
- the setting device can be completed by signalling the position of the blades.

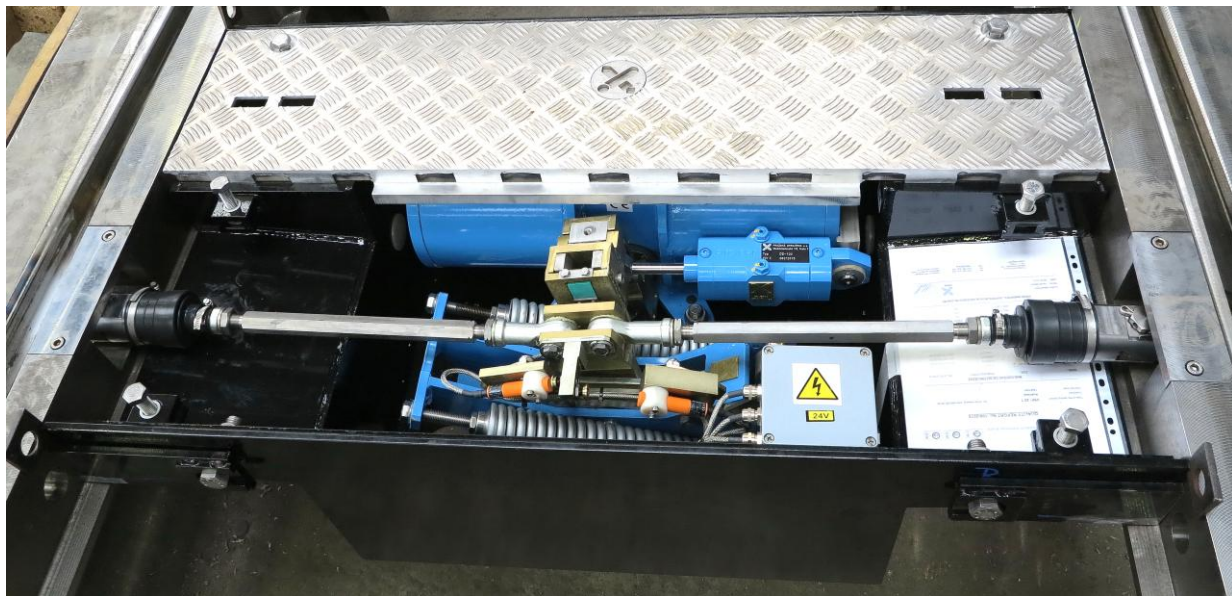

Electro-magnetic power device EMP-44



Electro-hydraulic power device EHP-41.

# Motorized pointing machine VSP-20

## Description:

1 - Earth case            2 - Earth case covers  
 3 - Patented pointing mechanism Z-75-R  
 4 - Setting rod  
 5 - Electro-magnetic power device with damper or  
 Electro-hydraulic power device  
 Device can be equipped by adaptor set with position  
 sensors.

All used materials guarantee high reliability and  
 moisture resistance.

Central drainage in earth case allow connection to  
 track drainage system.

## Technical parameters:

Minimum track gauge	od 1000 mm
Lift of changeable switch blades	36 to 70 mm
Connection setting rod/tongue	according turnout type
Setting force on the rod	cca 5 kN
Press-down force of spring mechanism	0,5 to 4 kN
Manual setting moment	80 to 350 Nm
Time of mechanized setting (adjustable)	0,6 to 1,5 s
Operational voltage of electro-magnetic power device	600 / 750 V DC
Operational voltage of electro-hydraulic power device	600 / 750 V DC
	230 / 400 V AC, 110 V AC 60 Hz
Normal current at 600 V DC	max. 10,5 A
Control voltage (control-free position sensors)	24 V DC
Permitted axle load on earthcase cover	12 000 kg
Earth case cover weight	50 kg
Overall weight	cca 450 kg

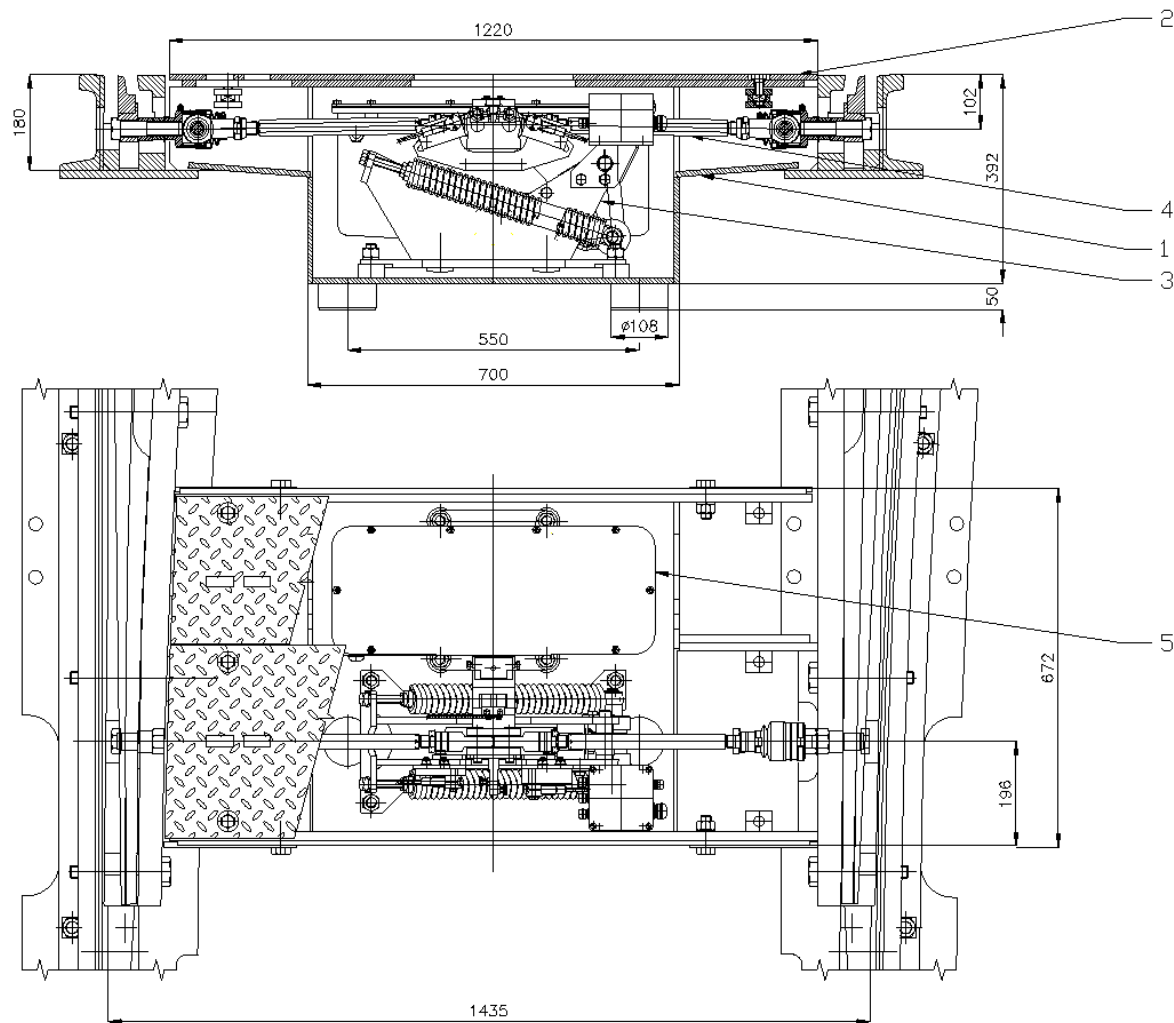

# Tramvajové výměny



block switch



switch with flexible blades



switch with replaceable blades



gauntlet switches



single point switches



heating the switches

## Tramway block switch

Tramway block switches are made for right and left branching and can be used as trailing or facing. They are constructed for use in the most demanding conditions of tramway tracks. They guarantee a high degree of passage safety, quiet function, are ecologically harmless and feature a long lifetime with minimum demands for maintenance.

### Securing:

- in cooperation with the facing or trailing direction setting system, an automated or manual resetting of the switch blades into the required direction and thus a safe tramway train passage in the straight or branching direction,
- the switch construction enables the use of modern, unified setting devices with the setting and checking rod.



# Tramway block switch

## Description:

The switch is made for grooved rails required by the consumer (NT1, 60R2, 60R1, 59R2, 59R1 ...). Each switch consists of two half switches set into the track gauge by means of distance rods. The half switch is a weldment from block rail quality R260 (R260V, eventually other quality) with the full-head rails NT (73C1, eventually other rail profile), there is a recess on the weldment for the changeable blade drilled at the machining CNC centres and the corresponding courses of grooves. The block switch can be produced in the sandwich design, where their the top segment of the switch is made from abrasion-resistant material and the lower part from the steel normal quality. The changeable blades are made from rail material or from abrasion-resistant steel (e.g. 400 and others) and into the block switch are fastened with a self-locking wedge. This self-locking wedge is secured against accidental loosing with a screw joint. The block switch is either welded on the underlay steel plate thickness 16mm, with which the switch is then fixed to the sleepers or its installation height is the same as the height of the rail. Both half switches are heated by heaters that are screwed to the side of the block switch, are replaceable and are stored in a stainless steel protector for easy replacement.

## Technical parameters:

Track gauge: according to the customer's needs (1435, 1000, 1067, 1524mm ...).

Rail profile: according to the customer's requirement (NT1, 60R2, 60R1, 59R2, 59R1 ...).

Branching radius: standard R 20, 25, 30, 50, 100 a 150m and or another, depending on the customer's needs.

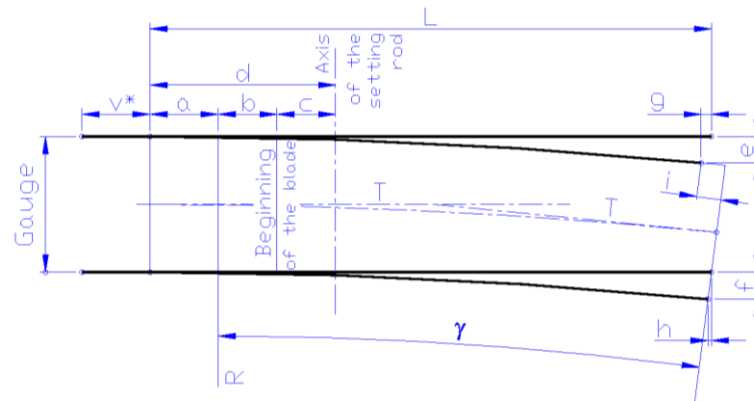

	R = 20 m		R = 25 m		R = 30 m		R = 50 m		R = 100 m		R = 150 m	
Rail	60R2, 60R1, 59R2, 59R1	NT1	60R2, 60R1, 59R2, 59R1	60R2, 60R1, 59R2, 59R1	60R2, 60R1, 59R2, 59R1	60R2, 60R1, 59R2, 59R1	NT1, NT3	60R2, 60R1, 59R2, 59R1, NT1	60R2, 60R1, 59R2, 59R1, NT1	60R2, 60R1, 59R2, 59R1, NT1	60R2, 60R1, 59R2, 59R1, NT1	
Gauge	1000	1435	1000	1435	1000	1435	1000	1435	1000	1435	1000	1435
L	4500	4500	3400	3400	4500	4500	4000	4000	5000	5000	4660	4660
v *	500	500	0	0	500	500	500	500	350	350	0	0
γ	11° 45' 11"	11° 53' 08"	9° 45' 18"	9° 45' 18"	9° 21' 16"	9° 26' 18"	7° 46' 06"	7° 49' 36"	5° 47' 14"	5° 48' 48"	5° 16' 25"	5° 16' 25"
	13,0589 g	13,2062 g	10,8390 g	10,8390 g	10,3938 g	10,4869 g	8,6322 g	8,8963 g	6,4305 g	6,4589 g	5,8595 g	5,8595 g
a	500	500	130	130	500	500	0	0	130	130	0	0
b	0	0	280	280	0	0	400	400	650	650	280	280
c	500	500	310	310	500	500	400	400	350	350	310	310
d	1000	1000	720	720	1000	1000	800	800	1000	1000	720	720
e	389	385	259	259	313	311	262	260	247	247	203	203
f	409	413	279	279	326	329	271	273	253	253	209	209
g	25	25	7	7	16	16	11	11	8	8	3	3
h	28	29	3	3	18	18	12	12	9	9	0	0
i	205	298	244	244	163	236	166	196	101	145	132	132
T	2059	2082	1707	1707	2045	2064	2037	2052	2527	2539	2303	2303
v *	is only in case of using electric heating according VDV											

## Tramway switch with flexible blades

Tramway switch with flexible blades are made for right and left branching and can be used as trailing or facing. They are constructed for use in the most demanding conditions of tramway tracks.

They guarantee a high degree of passage safety, quiet function, are ecologically harmless and feature a long lifetime with minimum demands for maintenance.

### Securing:

- in cooperation with the facing or trailing direction setting system, an automated or manual resetting of the switch blades into the required direction and thus a safe tramway train passage in the straight or branching direction,
- the switch construction enables the use of modern, unified setting devices with the setting and checking rod.



# Tramway switch with flexible blades

## Description:

The switch is made of grooved rails required by the customer (NT1, 60R2, 60R1, 59R2, 59R1 ...). Each switch consists of two half-switches set to the required gauge using spacers. The half-switch frames are made as weldments and are welded to the base plate along their entire length. The upper frames form sliding surfaces for the tongues. Both switch tongues (curved and straight) are welded, the rail part of the tongue is made of grooved rails of the customer's required profile and quality, and the flexible elastic part of the tongue is welded using approved technologies. The rail part of the tongue is welded to the base plate of the switch. Both half-switches are heated by heaters that are screwed to the side of the switch, are replaceable, and are housed in a stainless steel protector for easy replacement.

## Technical parameters:

Track gauge: according to the customer's needs (1435, 1000, 1067, 1524mm ...).

Rail profile: according to the customer's requirement (NT1, 60R2, 60R1, 59R2, 59R1 ...).

Branching radius: standard R 20, 25, 30, 50, 100 a 150m and or another, depending on the customer's needs.

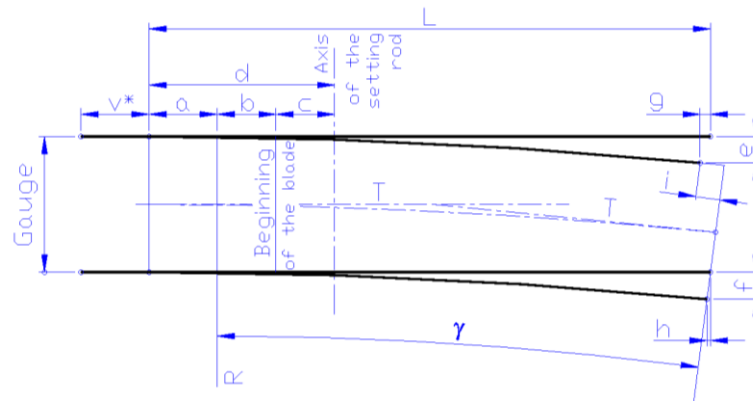

	R = 20 m		R = 25 m		R = 30 m		R = 50 m				R = 100 m		R = 150 m			
	60R2, 60R1, 59R2, 59R1	NT1	60R2, 60R1, 59R2, 59R1	60R2, 60R1, 59R2, 59R1	60R2, 60R1, 59R2, 59R1	60R2, 60R1, 59R2, 59R1	NT1, NT3		60R2, 60R1, 59R2, 59R1, NT1	60R2, 60R1, 59R2, 59R1, NT1	60R2, 60R1, 59R2, 59R1, NT1	60R2, 60R1, 59R2, 59R1, NT1				
Rail	1000	1435	1000	1435	1000	1435	1000	1435	1000	1435	1000	1435	1000	1435		
Gauge	1000	1435	1000	1435	1000	1435	1000	1435	1000	1435	1000	1435	1000	1435		
L	4500	4500	3400	3400	4500	4500	4000	4000	5000	5000	4660	4660	7000	7000	8500	8500
v *	500	500	0	0	500	500	500	500	350	350	0	0	200	200	0	0
γ	11° 45' 11"	11° 53' 08"	9° 45' 18"	9° 45' 18"	9° 21' 16"	9° 26' 18"	7° 46' 06"	7° 49' 36"	5° 47' 14"	5° 48' 48"	5° 16' 25"	5° 16' 25"	4° 01' 51"	4° 02' 23"	3° 15' 27"	3° 15' 44"
	13,0589 g	13,2062 g	10,8390 g	10,8390 g	10,3938 g	10,4869 g	8,6322 g	8,8963 g	6,4305 g	6,4589 g	5,8595 g	5,8595 g	4,4787 g	4,4885 g	3,6196 g	3,6249 g
a	500	500	130	130	500	500	0	0	0	130	130	0	0	0	0	0
b	0	0	280	280	0	0	400	400	650	650	280	280	800	800	1000	1000
c	500	500	310	310	500	500	400	400	350	350	310	310	400	400	400	400
d	1000	1000	720	720	1000	1000	800	800	1000	1000	720	720	1200	1200	1400	1400
e	389	385	259	259	313	311	262	260	247	247	203	203	243	243	240	240
f	409	413	279	279	326	329	271	273	253	253	209	209	246	246	242	242
g	25	25	7	7	16	16	11	11	8	8	3	3	6	6	4,5	4,5
h	28	29	3	3	18	18	12	12	9	9	0	0	6	6	4,5	4,5
i	205	298	244	244	163	236	166	196	101	145	132	132	70	101	57	82
T	2059	2082	1707	1707	2045	2064	2037	2052	2527	2539	2303	2303	3519	3527	4255	4272
v *	is only in case of using electric heating according VDV															

## Tramway switch with replaceable flexible blades

Tramway switch with replaceable flexible blades are made for right and left branching and can be used as trailing or facing. They are constructed for use in the most demanding conditions of tramway tracks. They guarantee a high degree of passage safety, quiet function, are ecologically harmless and feature a long lifetime with minimum demands for maintenance.

### Securing:

- in cooperation with the facing or trailing direction setting system, an automated or manual resetting of the switch blades into the required direction and thus a safe tramway train passage in the straight or branching direction,
- the switch construction enables the use of modern, unified setting devices with the setting and checking rod.



# Tramway switch with replaceable flexible blades

## Description:

The switch is made of grooved rails required by the customer (NT1, 60R2, 60R1, 59R2, 59R1 ...). Each switch consists of two half switches set to the required gauge using spacers. The half switch frames are made as weldments and are welded to the base plate along their entire length. The upper frames form sliding surfaces for the tongues. Both switch tongues (curved and straight) are replaceable – they are each fastened with four M20x1.5 screws for replacement and the position of the tongues is secured by a tongue-and-groove joint, the screw heads are secured against spontaneous loosening. The flexible elastic parts of the tongues are made of rail materials or wear-resistant steels. Both half-exchanges are heated by heaters that are screwed to the side of the exchange, are replaceable, and are housed in a stainless steel protector for easy replacement.

## Technical parameters:

Track gauge: according to the customer's needs (1435, 1000, 1067, 1524mm ...).

Rail profile: according to the customer's requirement (NT1, 60R2, 60R1, 59R2, 59R1 ...).

Branching radius: standard R 20, 25, 30, 50, 100 a 150m and or another, depending on the customer's needs.

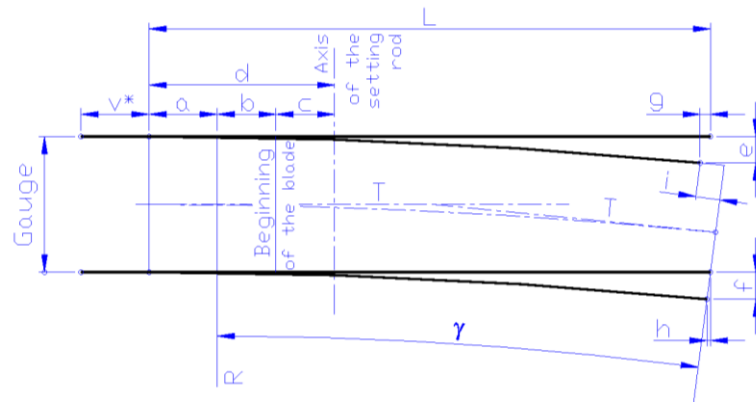

	R = 20 m		R = 25 m		R = 30 m		R = 50 m		R = 100 m		R = 150 m	
	60R2, 60R1, 59R2, 59R1	NT1	60R2, 60R1, 59R2, 59R1	60R2, 60R1, 59R2, 59R1	60R2, 60R1, 59R2, 59R1	60R2, 60R1, 59R2, 59R1	NT1, NT3	60R2, 60R1, 59R2, 59R1, NT1	60R2, 60R1, 59R2, 59R1, NT1			
Rail	1000	1435	1000	1435	1000	1435	1000	1435	1000	1435	1000	1435
Gauge	1000	1435	1000	1435	1000	1435	1000	1435	1000	1435	1000	1435
L	4500	4500	3400	3400	4500	4500	4000	4000	5000	5000	4660	4660
v*	500	500	0	0	500	500	500	500	350	350	0	0
γ	11° 45' 11"	11° 53' 08"	9° 45' 18"	9° 45' 18"	9° 21' 16"	9° 26' 18"	7° 46' 06"	7° 49' 36"	5° 47' 14"	5° 48' 48"	5° 16' 25"	5° 16' 25"
	13,0589 g	13,2062 g	10,8390 g	10,8390 g	10,3938 g	10,4869 g	8,6322 g	8,8963 g	6,4305 g	6,4589 g	5,8595 g	5,8595 g
a	500	500	130	130	500	500	0	0	130	130	0	0
b	0	0	280	280	0	0	400	400	650	650	280	280
c	500	500	310	310	500	500	400	400	350	350	310	310
d	1000	1000	720	720	1000	1000	800	800	1000	1000	720	720
e	389	385	259	259	313	311	262	260	247	247	203	203
f	409	413	279	279	326	329	271	273	253	253	209	209
g	25	25	7	7	16	16	11	11	8	8	3	3
h	28	29	3	3	18	18	12	12	9	9	0	0
i	205	298	244	244	163	236	166	196	101	145	132	132
T	2059	2082	1707	1707	2045	2064	2037	2052	2527	2539	2303	2303
v*	is only in case of using electric heating according VDV											

# Gauntlet tramway switches

Tramway gauntlet switches are manufactured as symmetrical or for right or left turns and can be used as facing or trailing switches. They are designed for use even in the most demanding conditions of tram lines.

They guarantee a high level of safety of passage, quiet operation, environmental friendliness and long-term service life with minimal maintenance requirements.

## Application:

Gauntlet tramway switches are used to switch tram sets to the appropriate branch at a certain required distance before the actual track branch. The axial distance of the running edges of both branches at the end of the switch is 129mm for a symmetrical switching point (symmetrically distributed from the original straight line) and 120mm for a right and left switch. The switch is followed by an arbitrarily long section with this given axial distance.

## Securing:

- in cooperation with the facing or trailing direction setting system, an automated or manual resetting of the switch blades into the required direction and thus a safe tramway train passage in the straight or branching direction,
- the switch construction enables the use of modern, unified setting devices with the setting and checking rod.



## Gauntlet tramway switches

### Description:

The gauntlet switches are manufactured for the profile of grooved rails required by the customer (NT1, 60R2, 60R1, 59R2, 59R1 ...). Each switch consists of two half switches set to the required gauge using spacers. The basis of the half switch is a weldment made of block quality steel R260 (R260V, other grades if applicable) with full head rails NT (73C1, or rails of a different profile); recesses for the changeable blades and corresponding groove courses are milled in the weldment on CNC machining centers. The changeable blades are made of rail material and are fixed in the switch with a self-locking wedge. The fixing self-locking wedge is secured against accidental loosening by a screw connection. The switch is either welded to a 16mm thick base plate, with which the switch is then attached to the sleepers, or its installation height is the same as the height of the rail. Both half switches are heated by heaters that are screwed to the side of the block switch, are replaceable and are housed in a stainless steel protector for easy replacement.

### Technical parameters:

Track gauge: according to the customer's needs (1435, 1000, 1067, 1524mm ...).  
 Rail profile: according to the customer's requirement (NT1, 60R2, 60R1, 59R2, 59R1 ...).

## SYMMETRICAL GAUNTLET SWITCH

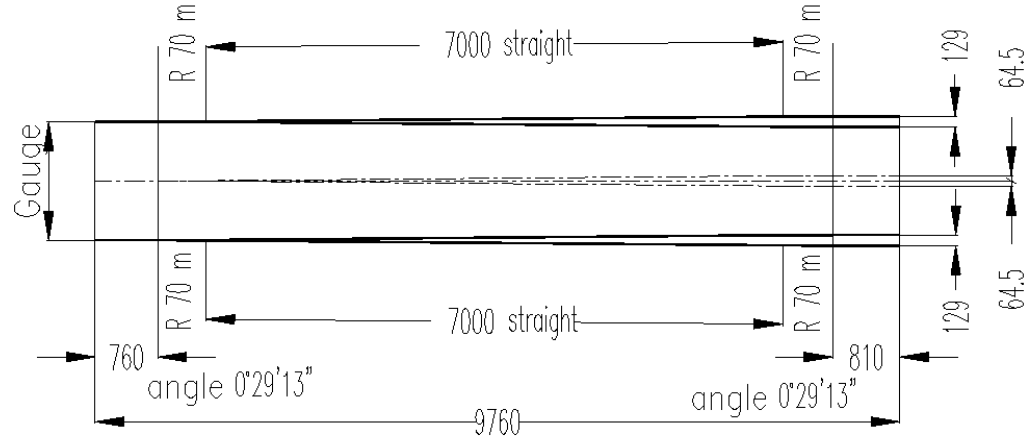

## GAUNTLET SWITCH RIGHT OR LEFT HANDED

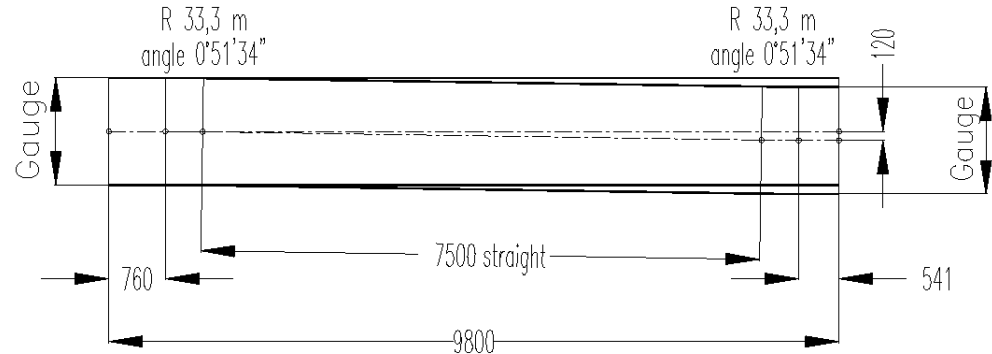

## Single-point tramway switches

Single-point tramway switches are made for right and left branching and can be used as trailing or facing. They are constructed for use in the most demanding conditions of tramway depots and tracks.

They guarantee a high degree of passage safety, quiet function, are ecologically harmless and feature a long lifetime with minimum demands for maintenance.

### Application:

Single-point tramway switches are used to allocate tram sets to the appropriate track, especially in special track structures such as harps in depots.

### Securing:

- in cooperation with the facing or trailing direction setting system, an automated or manual resetting of the switch blades into the required direction and thus a safe tramway train passage in the straight or branching direction,
- the switch construction enables the use of modern, unified setting devices with the setting and checking rod.



# Single-point tramway switches

## Description:

The single-point switches are manufactured for the profile of grooved rails required by the customer (NT1, 60R2, 60R1, 59R2, 59R1 ...). The basis of a single-point switch is a weldment made of slab steel R260 (R260V, other grades if applicable) with full-head rails NT (73C1, or rails of a different profile). The weldment is milled on CNC machining centers with recesses for the changeable blade and corresponding groove courses. The changeable blade is made of rail material or abrasion-resistant materials (e.g. Dillidur 400 and others) and is fixed in the exchange with a self-clamping wedge. The fixing self-clamping wedge is secured against accidental loosening by a screw connection. A non-blade half is standardly manufactured as a weldment made of special profiles or forgings, subsequently machined on CNC centers. The half switch with the blade is heated.

## Technical parameters:

- Track gauge: according to the customer's needs (1435, 1000, 1067, 1524mm ...).
- Rail profile: according to the customer's requirement (NT1, 60R2, 60R1, 59R2, 59R1 ...).
- Branching radius: standard R 20, 25, 30, 50 and or another, depending on the customer's needs.

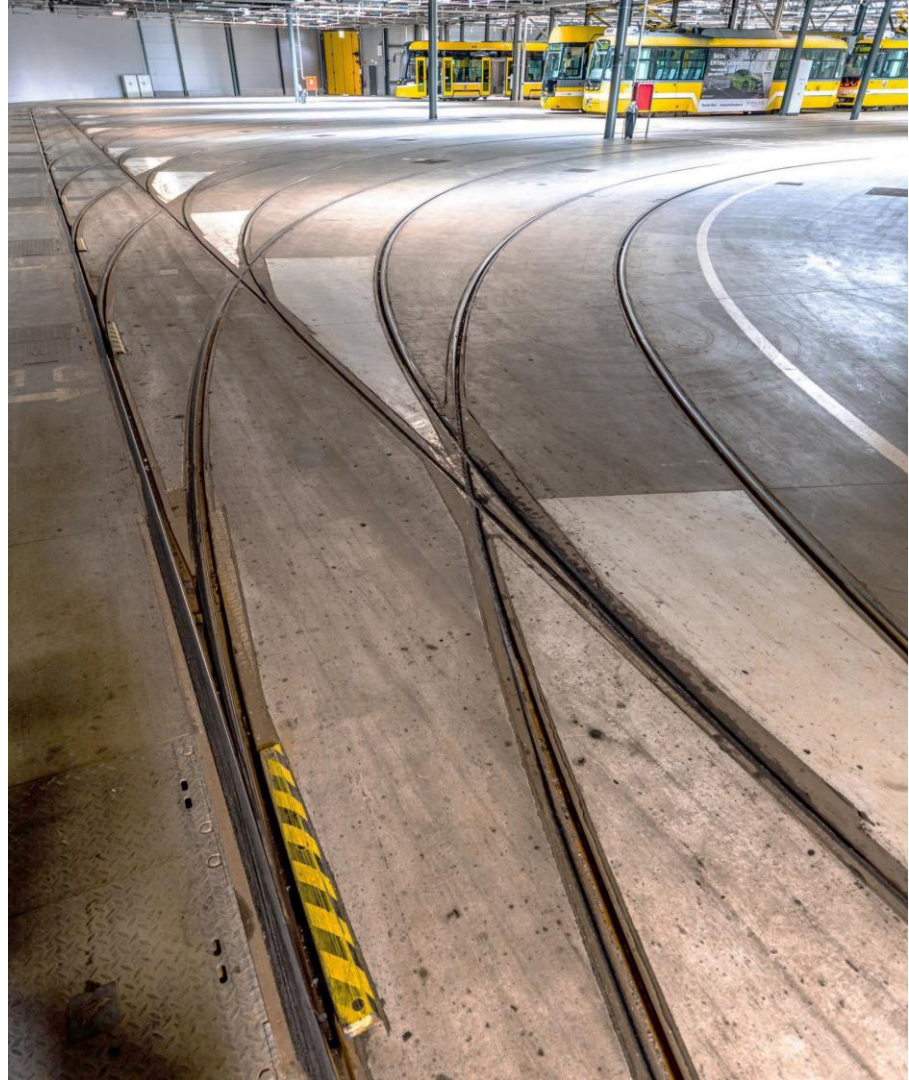

## Heating the switches

The device is used to heat switches with flexible or pivot tongues to ensure their proper functioning at air temperatures below freezing and in adverse weather conditions (icing, snowfall). The heating can be operated either as unregulated (direct switching on and off of the heating) or as regulated depending on the outdoor temperature. The direct or regulated heating function can be selected by setting the heating mode in the switch control system.



# Heating the switches

## Securing:

- Heating of switches to ensure their proper functioning at air temperatures below freezing and in adverse weather conditions (icing, snowfall).

## Technické parametry:

heater type according to requirement  
nominal operating voltage of the heater standard 600V DC (750V DC, 220V AC)  
heater power 600W or 900W  
electrical protection of the heater connection IP - 68  
heater dimensions heating element dia. 8mm length 2200mm or other according to requirement

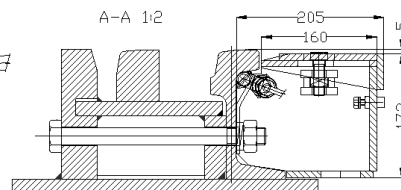
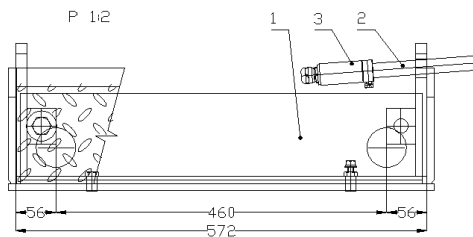
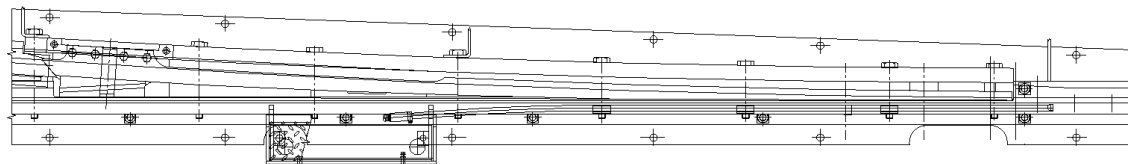
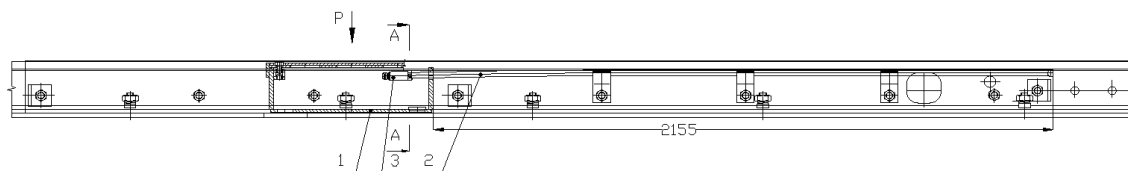

# Tournouts and crossings



Tournouts with a straight section in the branching direction



Tournouts with a curved section in the branching direction



Flat bottom LRT turnouts - T rail



mobil cross-over



crossings



training, service and maintenance

## Tournouts with a straight section in the branching direction

Tramway tournouts are made for right and left branching and can be used as trailing or facing. They are constructed for use in the most demanding conditions of tramway tracks.

They guarantee a high degree of passage safety, quiet function, are ecologically harmless and feature a long lifetime with minimum demands for maintenance.

### Securing:

- in cooperation with the facing or trailing direction setting system, an automated or manual resetting of the switch blades into the required direction and thus a safe tramway train passage in the straight or branching direction.



# Tournouts with a straight section in the branching direction

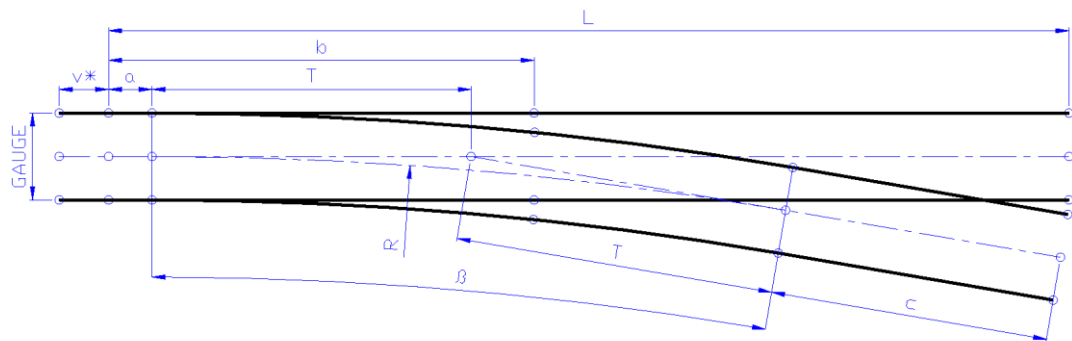

## Description:

The switches are made of grooved rails of the profile required by the customer (60R2, 60R1, 59R2, 59R1 ...). The switch is a standard construction in accordance with VDV regulations. The grooved part is made of a weldment from the frog (profile 310C1 of quality R220G1 or other required quality) and welded rail parts (full-head rail 73C1, 105C1 of the required quality) with milled height and side ramps. The retaining grooved rails located in the gauge opposite the frog are made of full-head rail 73C1 or the relevant rail required by the customer.

## Technical parameters:

Track gauge: according to the customer's needs (1435, 1000, 1067, 1524mm ...).

Rail profile: according to the customer's requirement (NTI, 60R2, 60R1, 59R2, 59R1 ...).

Branching radius: standard R 20, 25, 30, 50, 100 a 150m and or another, depending on the customer's needs.

	1:4		1:6		1:7		1:9	
Rail	60R2, 60R1, 59R2, 59R1		60R2, 60R1, 59R2, 59R1		60R2, 60R1, 59R2, 59R1		60R2, 60R1, 59R2, 59R1	
Gauge	1000	1435	1000	1435	1000	1435	1000	1435
R	25 m	25 m	50 m	50 m	100 m	100 m	150 m	150 m
L	9640	11406	12372	15000	16439	19500	19465	23650
v *	500	500	350	350	200	200	0	0
β	14° 02' 10"	14° 02' 10"	9° 27' 44"	9° 27' 44"	8° 07' 48"	8° 07' 48"	6° 20' 24,7"	6° 20' 24,7"
	15,5958 g	15,5958 g	10,5137 g	10,5137 g	9,0334 g	9,0334 g	7,0447 g	7,0447 g
a	500	500	0	0	0	0	0	0
b	4500	4500	5000	5000	7000	7000	8500	8500
c	2984	4750	4096	6724	2225	5286	3149	7034
T	3078	3078	4138	4138	7107	7107	8308	8308
v *	is only in case of using electric heating according VDV							

## Tournouts with a curved section in the branching direction

Tramway tournouts are made for right and left branching and can be used as trailing or facing. They are constructed for use in the most demanding conditions of tramway tracks.

They guarantee a high degree of passage safety, quiet function, are ecologically harmless and feature a long lifetime with minimum demands for maintenance.

### Securing:

- in cooperation with the facing or trailing direction setting system, an automated or manual resetting of the switch blades into the required direction and thus a safe tramway train passage in the straight or branching direction.



# Tournouts with a curved section in the branching direction

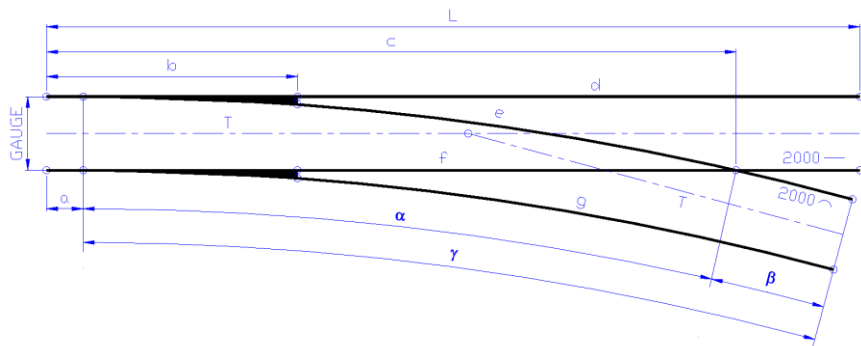

## Description:

The switches are made of grooved rails of the profile required by the customer (60R2, 60R1, 59R2, 59R1 ...). The switch is a standard construction in accordance with VDV regulations. The grooved part is made of a weldment from the frog (profile 310C1 of quality R220G1 or other required quality) and welded rail parts (full-head rails 73C1, 105C1 of the required quality) with milled height and side ramps. The retaining grooved rails located in the gauge opposite the frog are made of lead rail 73C1 or the relevant rail required by the customer.

## Technical parameters:

Track gauge: according to the customer's needs (1435, 1000, 1067, 1524mm ...).

Rail profile: according to the customer's requirement (NT1, 60R2, 60R1, 59R2, 59R1 ...).

Branching radius: standard R 20, 25, 30, 50, 100 a 150m and or another, depending on the customer's needs.

	R = 20 m		R = 25 m		R = 30 m		R = 50 m		R = 100 m		R = 150 m	
Rail	60R2, 60R1, 59R2, 59R1		60R2, 60R1, 59R2, 59R1		60R2, 60R1, 59R2, 59R1		60R2, 60R1, 59R2, 59R1		60R2, 60R1, 59R2, 59R1		60R2, 60R1, 59R2, 59R1	
Gauge	1000	1435	1000	1435	1000	1435	1000	1435	1000	1435	1000	1435
L	8825	10076	9571	10970	9746	11279	12000	13979	16142	18941	19320	22748
v *	500	500	500	500	500	500	350	350	200	200	0	0
α	17° 58' 11,2"	21° 27' 01,2"	16° 05' 56,2"	19° 13' 49,6"	14° 42' 44"	17° 34' 56"	11° 25' 16,3"	13° 39' 43,1"	8° 05' 21,7"	9° 41' 00"	6° 36' 31"	7° 54' 46"
	19,96642 g	23,8337 g	17,88771 g	21,36716 g	16,3470 g	19,5359 g	12,69022 g	15,17997 g	8,98818 g	10,75926 g	7,3429 g	8,7919 g
β	5° 35' 23,4"	5° 31' 52,1"	4° 29' 37,6"	4° 27' 21"	3° 45' 25,6"	3° 43' 49,8"	2° 16' 08,9"	2° 15' 33,9"	1° 08' 24,8"	1° 08' 16"	0° 45' 41"	0° 45' 37"
	13,0589 g	13,2062 g	4,99309 g	4,95093 g	4,17456 g	4,1450 g	6,4305 g	6,4589 g	4,4787 g	4,4885 g	0,8460 g	0,8448 g
γ	23° 33' 34,6"	26° 58' 53,3"	20° 35' 33,8"	23° 41' 10,6"	18° 28' 12"	21° 18' 48"	13° 41' 25,2"	15° 55' 17"	9° 13' 46,5"	10° 49' 16"	7° 22' 12"	8° 40' 23"
	13,0589 g	13,2062 g	22,88080 g	26,31809 g	20,5223 g	23,6816 g	6,4305 g	6,4589 g	4,4787 g	4,4885 g	8,1889 g	9,6367 g
a	500	500	500	500	0	0	0	0	0	0	0	0
b	4500	4500	4500	4500	4000	4000	5000	5000	7000	7000	8500	8500
c	6825	8076	7571	8970	7746	9279	10000	11979	14142	16941	17320	20748
d	4325	5576	5071	6470	5746	7279	7000	8979	9142	11941	10820	14248
e	2430	3756	3165	4632	3831	4526	5067	7093	7189	10022	8859	12315
f	2325	3576	3071	4470	3746	5279	5000	6979	7142	9941	8820	12248
g	4018	5080	4805	6038	5509	6892	6828	8695	9028	11751	10730	14097
T	4171	4798	4542	5242	4878	5645	6002	6992	8072	9471	9661	11375

v \* is only in case of using electric heating according VDV

## Flat bottom LRT turnouts – T rail

The flat bottom turnouts are designed for high-speed tramway tracks and LRT tracks. Turnouts are manufactured from rails in the profile and the quality required by customer in Left and Right configurations. Modern design results in a high level of safety, silent and environmentally friendly operation, and a long life with minimal maintenance requirements.

### Advantages:

- Safe and smooth passage in a straight or branching direction, in cooperation with a manual or automated facing or trailing setting system.
- Construction enables the use of modern unified setting devices with setting and checking rods.
- Minimal maintenance requirements.



## Flat bottom LRT turnouts – T rail

### Description:

Turnouts are in a standard design that is compliant with VDV regulations. Stock rails are manufactured from 49E1 rails, grade R260, tongues from 49E1A1, grade R260, and guide rails from 33C1 profile. Tongues are placed on sliding phosphate stools and roller idlers SCHWIHAG that are mounted to sleepers. Stock rails are fixed in a flexible manner along the entire length using SkI12KTL and flexible Ssb2 braces SCHWIHAG that pass through the internal part of the idlers. Between stock rails and tongues tongue supports and locks are placed to avoid mutual movement. Both turnout branches are electrically wired using copper rope with a conical pin and a M16 bolt. Switch heating is provided by 8 heating elements consisting of resistive conductors in 11 x 5,5 mm oval stainless pipe. Heating elements are fixed to stock rails and tongues by flexible stainless clips and fix braces at the beginning.

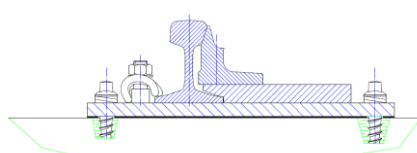

Section of the switch at the beginning of the tongue

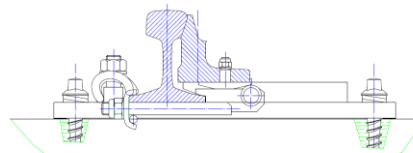

Section of the switch in area of roller idler

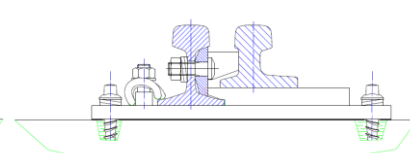

Section in area of tongue support

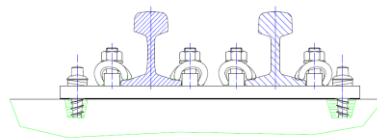

Section in area of switch end

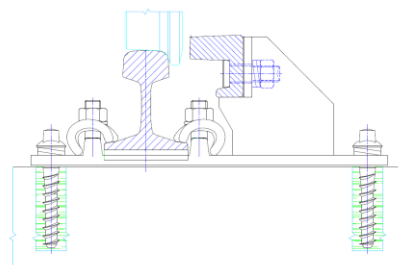

Section in area of guide-rail location

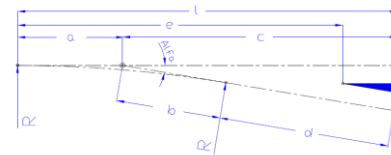

Type	1:6	1:7,5	1:6,6	1:7,5	1:9	1:9	1:11	1:12	1:14	1:18,5
Radius	R150	R150	R190	R190	R190	R300	R300	R500	R760	R1200
Rail	49E1	49E1	49E1	49E1	49E1	49E1	49E1	49E1	49E1	49E1
Gauge	1435	1435	1435	1435	1435	1435	1435	1435	1435	1435
a	12414,5	9956	14312	12611	10523	16615,5	13608,5	20797	27108	32409
b	12414,5	9956	14312	12611	10523	16615,5	13608,5	20797	27108	32409
c	12414,5	12944	15727	12611	16615	16615,5	20000	20797	27108	32409
d	-	2988	1415	-	6092	-	6391,5	-	-	-
e	20748,5	20766	23356	23352	23478	29343	29426	37881	46704	58686
L	24829	22900	30039	25222	27138	33231	33608,5	41594	54216	64818
Alpha	9° 27' 44,45"	7° 35' 40,72"	8° 36' 56,33"	7° 35' 40,72"	6° 20' 24,69"	6° 20' 24,69"	5° 11' 39,94"	4° 45' 49,11"	4° 05' 08,22"	3° 05' 38,61"

## Portable cross-over

### Provide:

Portable cross-over is designed for use at current embedded double line tramway tracks in straight sections without ground waves as a temporary turn-around for double direction trams or for temporary transmission of traffic to one of the lines during track construction.

It is flexible and can easily be modified by adaptor section to different track centers.



# Mobile Crossover as temporary back-around for double direction tram trains

CHANGE OF  
MOVEMENT  
DIRECTION

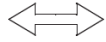

TRACK - A

TRACK - B

TRACK IN  
RECONSTRUCTION

OUTBOUND



INBOUND

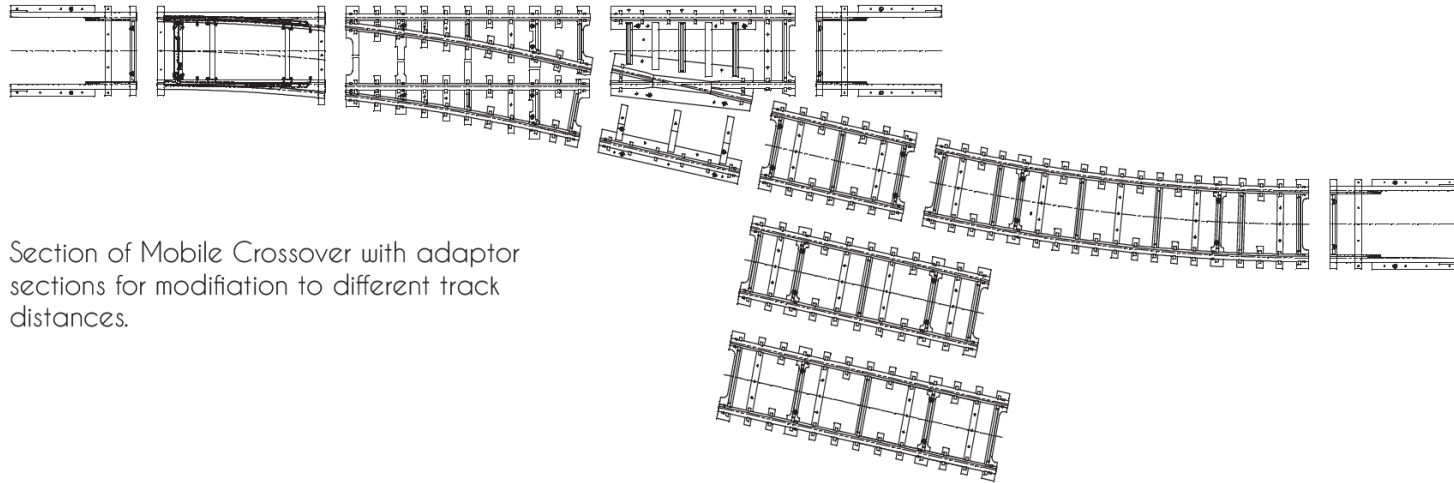

Section of Mobile Crossover with adaptor sections for modification to different track distances.

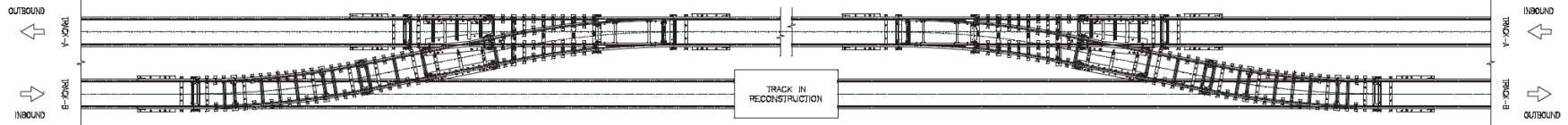

# Tramway crossing

## Description:

For the production of crossings Pražská strojírna a.s. uses its own standard and special turnouts, switches, point systems, heating and drainage components. Thanks to our own applied research, Pražská strojírna a.s. can solve special and demanding requirements such as the usage of special abrasion-resistant materials like Hardox and Dillidur, for production of frogs at extremely exposed areas etc. All constructed materials are welded in accordance with approved technologies and standards. The technical specification of rail construction is an inseparable part of its definition (courses and shapes of grooves in crossings, production clearances, inspection, description of the rail construction, transport units, technical documentation supplied with product, etc.) As basic material for manufacturing of tramway rail crossings, grooved rails are used with required profile (NT1, 60R2, 60R1, 59R2, 59R1, 55R1, 57R1...) and required quality (R200, R220, R260, R260V, R290, R290GHT-CL etc.). Shallow or narrow grooved crossings and frogs are made from full-head rail profiles and steel blocks in quality R260, as standard in accordance with German VDV standards. Any exposed surfaces can be treated by hard-weld overlay. Pražská strojírna a.s. also carries out guarantee and post-guarantee services for all of its products upon agreement.



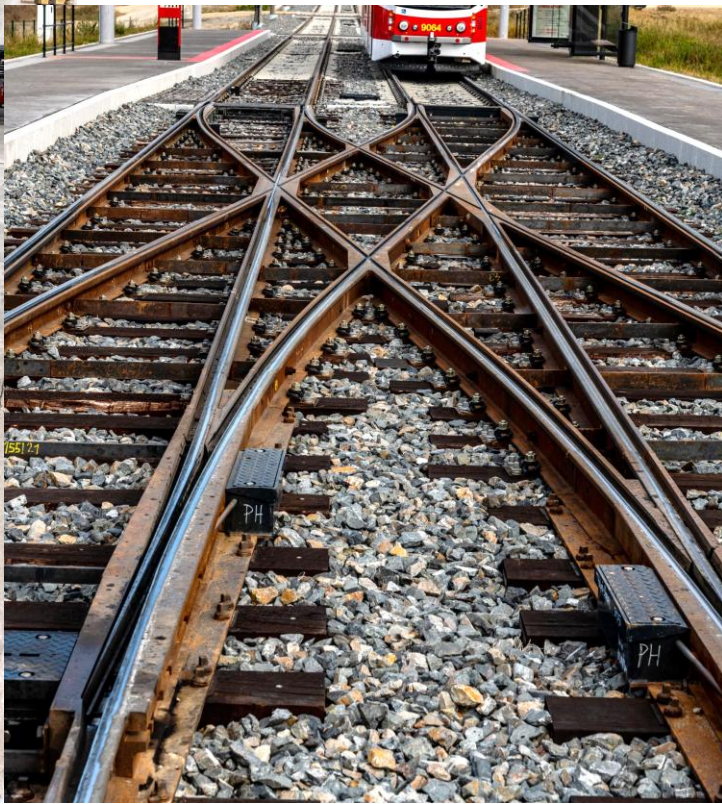
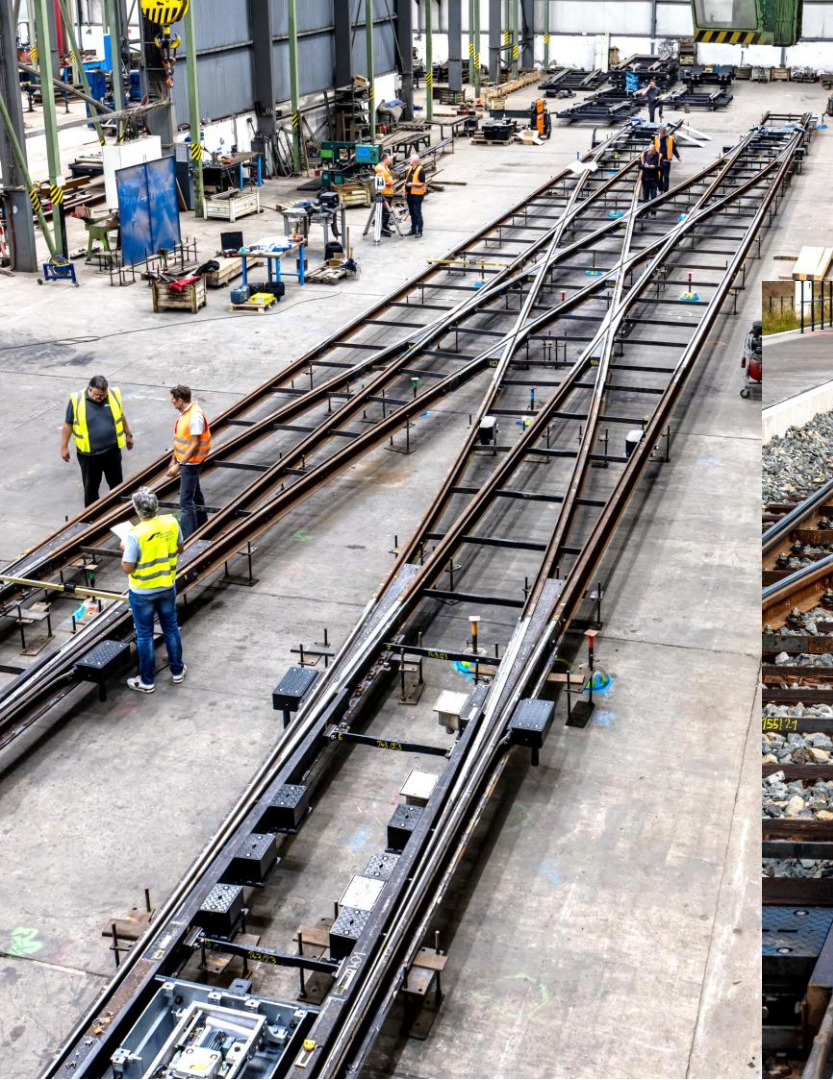

# Expansion rails, transition rails and other track equipment

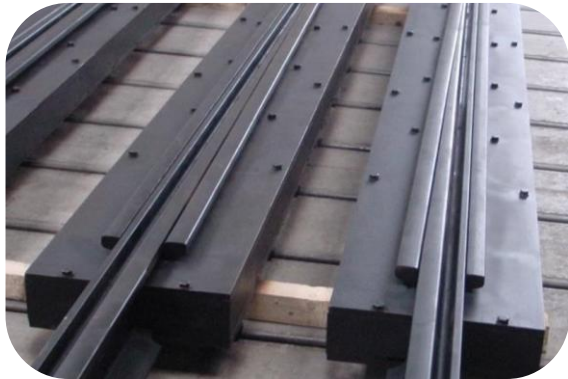

expansion rails, transition rails

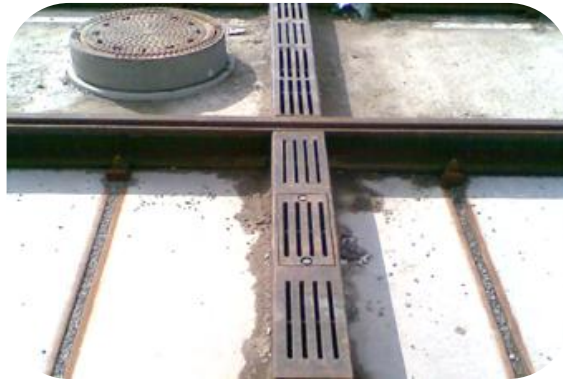

drainage



profil Spurrillenschiene 49E1 (Krug)

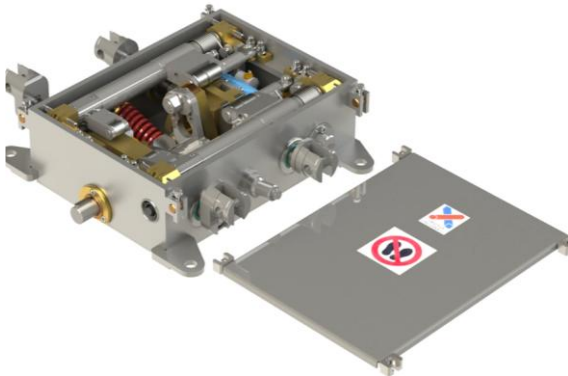

design work



wheels and wheel tyres



training, service and maintenance

# Expansion rails, transition rails and other track equipment

## Description:

Pražská strojírna a.s. produces transition rails between two different profiles of grooved rails or between grooved rails and vignole rails.

Pražská strojírna also produces expansion rails in two basic designs:

a) Expansion rails for common use in tram lines with an expansion step of  $\pm 35\text{mm}$ .

b) Bridge expansion rails - enable tram sets to cross from solid ground to bridges and back. The expansion step is determined by the size of the expansion movement of the bridge and commonly produced expansions solve expansion movements of e.g.  $\pm 200\text{mm}$ .

Transition rails can also be combined with expansion rails.

Pražská strojírna a.s. also produces various other small track equipment for specific customer needs.

## Provide:

- Transition rails ensure the passage of a tram set between two different rail profiles along a factory-made joint of two different rail profiles.
- Expansion rails enable the expansion movement of individual rail strips and structurally solve the crossing of tram sets.



## Expansion rails, transition rails and other track equipment

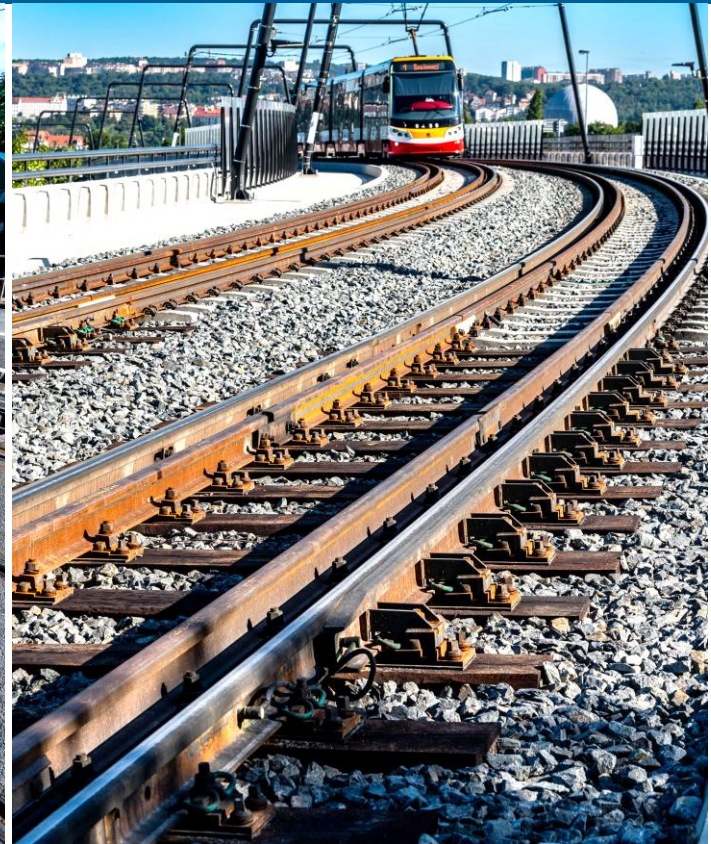
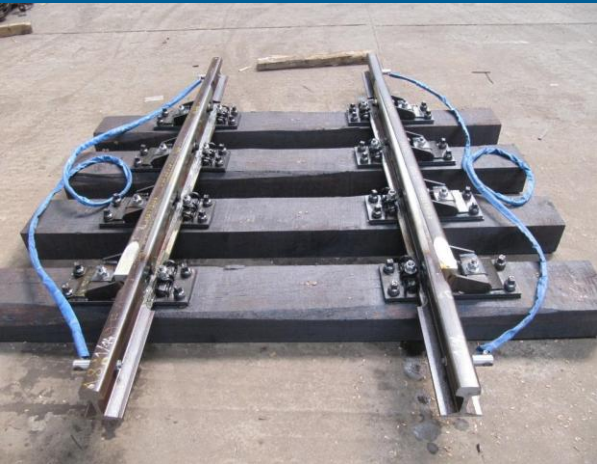

# Tramway drainage system

## Description:

A comprehensive solution for tram line drainage allows for the drainage of the entire width of the tram line or part of it, both in sections used by road vehicles and in grassed sections.

## Provide:

- complete drainage of the tram track surface,
- drainage of the rail groove.

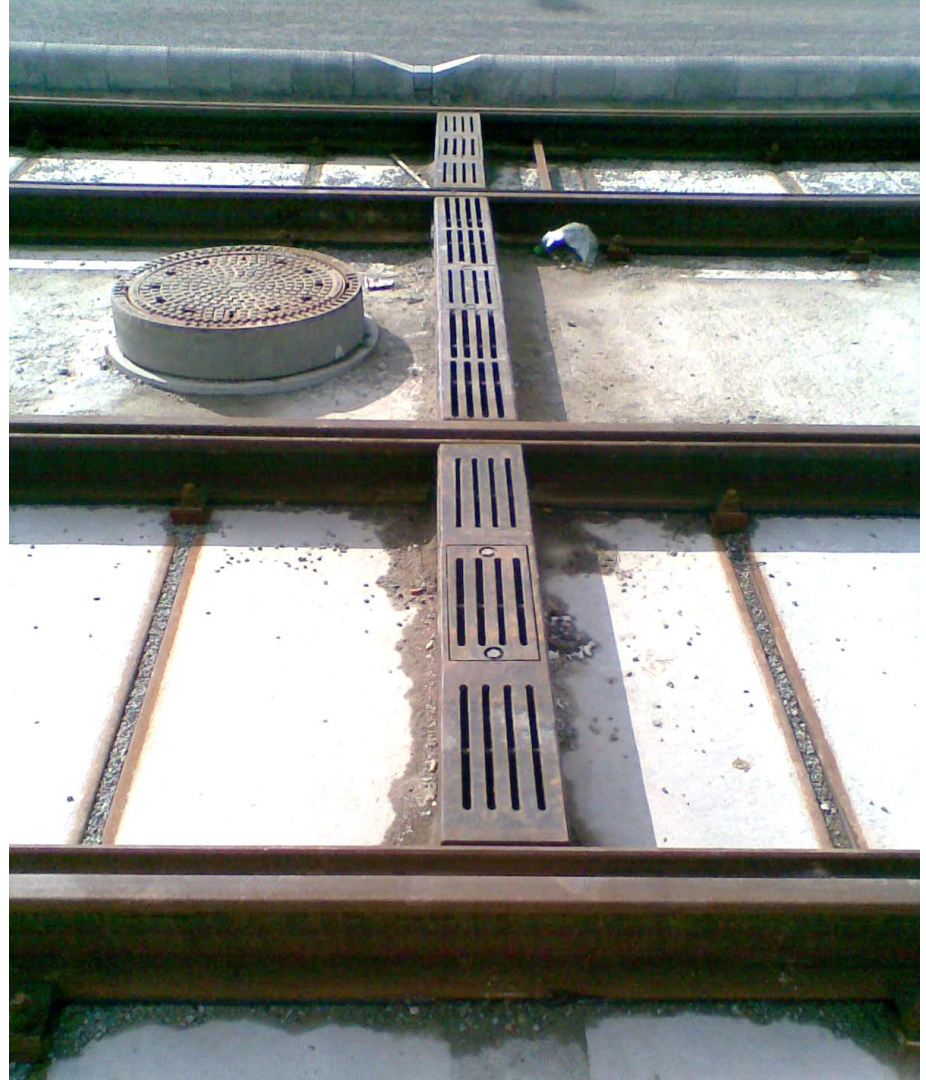

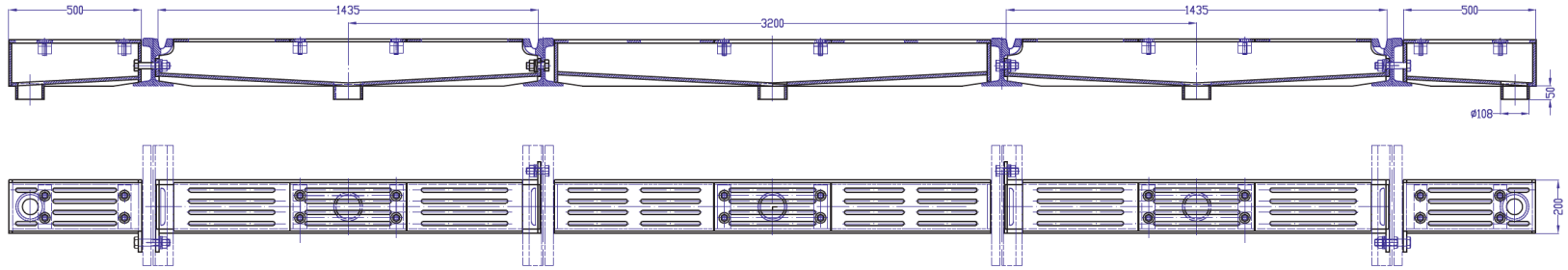

### 1. Complex self-supporting section system – side drainage – in-gauge drainage – intermediate drainage.

- Each section allows independent application.
- In-gauge section allows collection of water from track surface and rail grooves.
- Solid welded construction.
- Easy application to existing track with no need to remove rails.
- Noise-less in road traffic.
- Available in lengths according project needs.
- Easy connection to track central drainage system.



### 2. Casted or welded body with removable cover

- Fitted to rail by two bolts with rubber spacers
- 100 mm outlet for drainage hose

## Profile Spurrillenschiene 49E1 (Krug)

### Application:

The Spurrillenschiene S49 profile is supplied in bars of 15 m length. Pražská strojírna a.s. offers pre-drilling of holes for special fastening screws and, if necessary, shortening to the required length. We supply the profile with original M22x90 screws, washers and M22 nuts for attachment to the 49E1 rail (S49).

The profile is used as a support in curves of tram lines or as a groove profile for tram line crossings. Another possible use is when doubling the profile on both sides of the 49E1 rail for crane tracks.

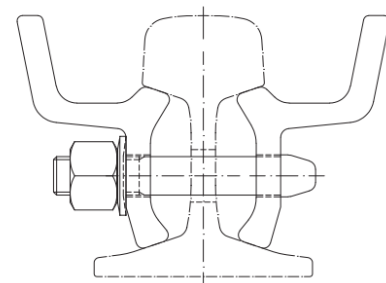
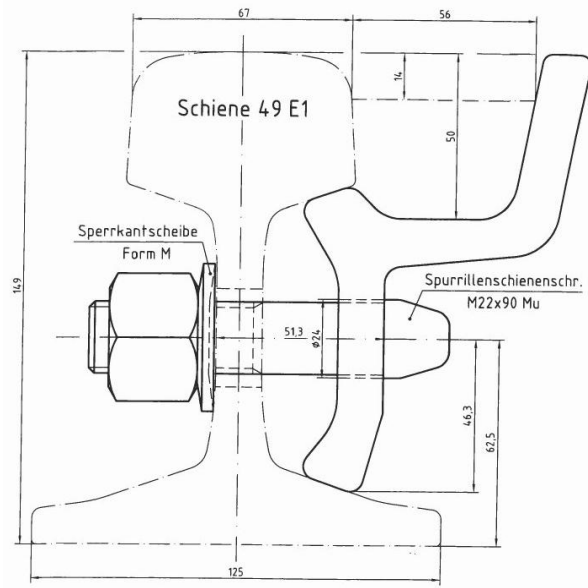

# Profile Spurrillenschiene 49E1 (Krug)



Railings made of Spurrillenschiene 49E1 profile in the radius in Liberec



1) Use as a retaining wall in curves on tram lines

2) Use as a retaining wall in tramway curves Use as a groove profile for tramway overpass



Grooved profile  
Spurrillenschiene 49E1 pre-  
assembled in Pražská strojirna  
a.s. on concrete sleepers and  
installed in Prague

## Design work

**Pražská strojírna a.s.** has been engaged in the development and production of railway crossings and complete track superstructure accessories for more than a century, using its own top-notch design capabilities. Our experienced designers, who work with modern CAD systems, especially advanced 3D modeling software, create detailed digital models and then derive precise drawings for production processes and inspection operations from them. This software allows for complex design designs of machine and equipment assemblies, including individual components such as workpieces, welded structures or sheet metal parts.

Part of the technical preparation of production is also the creation of CNC programs in the CAM system for advanced production machines, including milling machines, multi-axis machining centers, lathes, carousels and other specialized equipment. This process ensures high accuracy and efficiency in the processing of individual parts and complete assemblies.

In cooperation with professional geodetic and design offices, we prepare detailed production documents for the reconstruction, repair and modernization of railway lines and crossings. This process includes precise geodetic surveying, technical analyses and subsequent implementation of tailor-made solutions that meet the highest standards of safety and operational reliability. Thanks to the combination of tradition, modern technologies and expertise, Pražská strojírna a.s. has long contributed to the development and sustainability of rail transport not only in the Czech Republic, but also internationally.

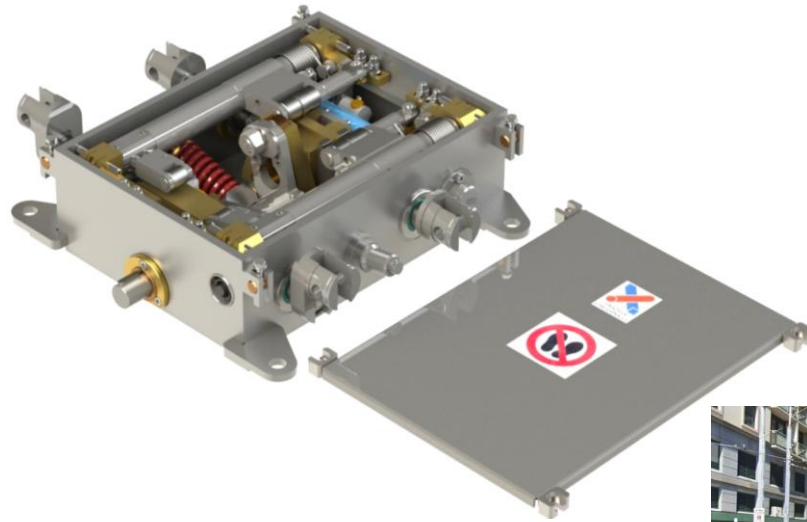



## Wheels and wheel tyres

**Pražská strojírna a.s.** as part of our production program, we also supply new tram wheels and machined wheel tyres for tram vehicles in various profiles and types according to customer requirements. Wheels and tyres represent a significant segment of spare parts and we supply them for various types of trams. Spare parts are manufactured using the same strict standards, procedures and testing methods as original products. After the modern Škoda trams were put into operation, we expanded the production of wheels and wheel tyres not only for the original ČKD series vehicles, but also for new modern types of wheels and tyres since 2000. We currently produce various wheel profiles and wheel tyres for various types of trams with various running profiles in the amount of thousands of wheels per year, not only for transport companies in the Czech Republic but also abroad. As a standard, we supply them up to a diameter of 800 mm and a weight of up to 120 kg. We supply wheels and tyres completely machined with a running profile specified by the customer. The most commonly used material is B6 steel (tensile strength 920 – 1050 N/mm<sup>2</sup>; hardness 269 – 311 HB), but other grades are also possible (e.g. B7, C3).

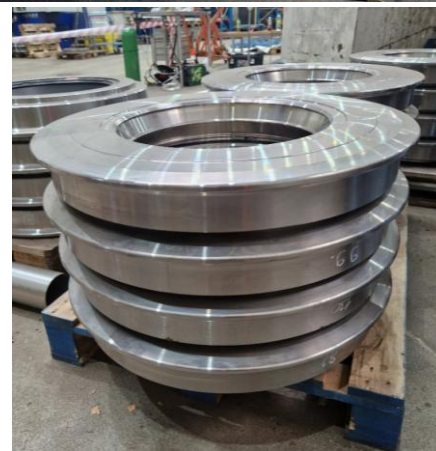
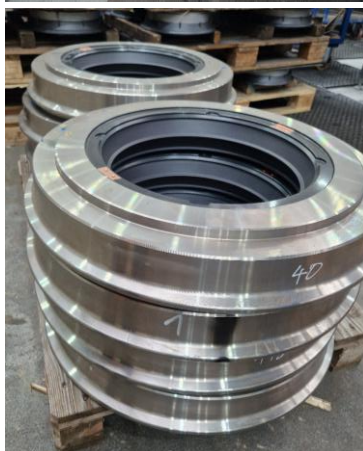

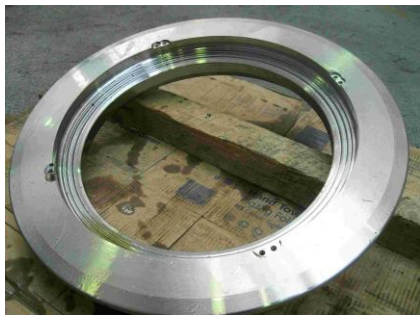

For turning tram tyres and monoblock wheels, we use two vertical lathes – carousels with a rotary tool drive (C axis).  
Carousel parameters:

- max. rotating diameter 1400mm,
- diameter of the table clamping surface 1000mm,
- max. workpiece height 1200mm,
- max. workpiece weight 5000 kg.



Other options of Prazska strojirna a.s. in the field of production and renovation of tram wheels:

- production of tram monoblocks from 42CrMo4 material (drop forging),
- reconditioning of wheels:
  - o composite wheel,
  - o sprung wheel,
  - o surface treatment of wheel components:
    - painting,
    - removal of old paint in a blasting cabin (balloting),
  - o disassembly and pressing of sprung wheels.



## Rail surfacing – re-shaping of the rail

Side surfacing of track rails in radiuses with subsequent grinding into a required profile represents the most cost-effective way of prolonging the rail lifespan. Quality surfacing postpones the necessity for the greatly more expensive and complicated rail exchange.

Our process of profile renewal by surfacing is based on using a Cr18Ni8Mn6 chemical composition wire (additional material), which complies with the plasticity requirement of individual sections of the surfaced rail system. We achieve a 30% of difference in the hardness of the overlay in comparison with the base material. The mechanical properties of the overlay can be further enhanced by inserting an additional layer with a higher manganese content, which increases the abrasion resistance by approximately 30%. The job is performed by qualified crews, which are regularly examined by a welding authority. Thorough preparation is a matter of course – the surface is cleaned by grinding and preheated at a low temperature. The rail grinding tools are effective enough to perfectly grind the overlays into the required shape.

Pražská strojírna a.s. currently owns three automatic surfacing flux units with an individual capacity of 20m grinded overlay per shift, respectively 30m per 12-hour extended shift.

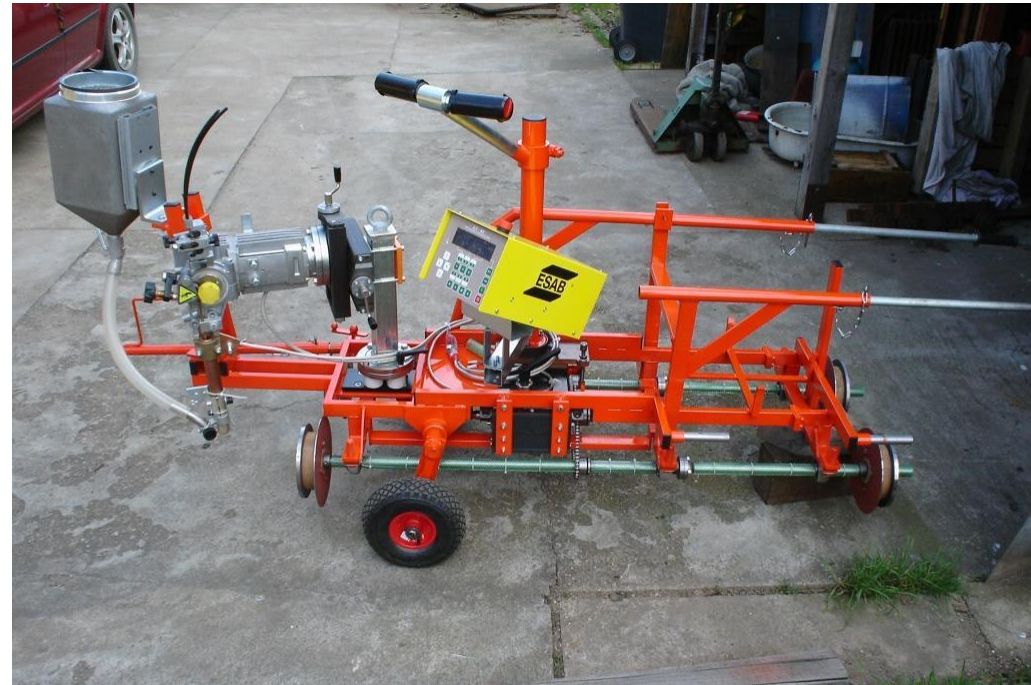

## Welding of rails under flux



## Grinding of corrugated rails

Rail corrugation is often an underestimated factor. Firstly, it causes an increased level of noise, which is a common and justified subject of local complaint. Aside from this it always leads to serious destruction of the entire track including the track bed. The dynamic shocks are relayed to the surrounding buildings, resulting in their subsequent static damage. In order to deal with rail corrugation, Pražská strojírna a.s. possesses two grinders, each of which is capable of grinding approximately 400 m per shift. The machines work on the principle of rotating grinding drums. These machines have proven themselves in Prague over the course of many years. DP Prague runs tram transportation around the clock, and incidental exclusions are undesirable. Thanks to their design our grinding machines are suitable for use during tram operation, as making the way for tram coming can be done almost instantly. In the case of a necessity of greater performance, we are able to provide a machine that is able to grind 2,000 m of rails per shift. This machine, however, requires tram line exclusion.





# Pražská strojírna a.s.



Mladoboleslavská 133, 190 17 Praha 9 – Vínohř



+420 283 112 201



[info@pstroj.cz](mailto:info@pstroj.cz)



[www.pstroj.cz](http://www.pstroj.cz)

